

3-26-2009

# Smart Grid Reliability Assessment Under Variable Weather Conditions

Arif Islam

*University of South Florida*

Follow this and additional works at: <http://scholarcommons.usf.edu/etd>

 Part of the [American Studies Commons](#), and the [Electrical and Computer Engineering Commons](#)

---

## Scholar Commons Citation

Islam, Arif, "Smart Grid Reliability Assessment Under Variable Weather Conditions" (2009). *Graduate Theses and Dissertations*.  
<http://scholarcommons.usf.edu/etd/3483>

This Dissertation is brought to you for free and open access by the Graduate School at Scholar Commons. It has been accepted for inclusion in Graduate Theses and Dissertations by an authorized administrator of Scholar Commons. For more information, please contact [scholarcommons@usf.edu](mailto:scholarcommons@usf.edu).

Smart Grid Reliability Assessment Under Variable  
Weather Conditions

by

Arif Islam

A dissertation submitted in partial fulfillment  
of the requirements for the degree of  
Doctor of Philosophy  
Department of Electrical Engineering  
College of Engineering  
University of South Florida

Major Professor: Alexander Domijan, Jr., Ph.D  
Huseyin Arslan, Ph.D  
Thomas L. Crisman, Ph.D  
James R. Mihelcic, Ph.D  
Stephen E. Sadow, Ph.D

Date of Approval:  
March 26, 2009

Keywords: Power Distribution System, Reliability Analysis, Reliability Improvement,  
Microgrid, Reconfiguration for Restoration

© Copyright 2010, Arif Islam

## **DEDICATION**

To my parents Sarwat Perveen and Sarwat Islam  
Brothers Humayun and Asif,  
Sisters Darakhshan, Kehkashan and Shehla  
To my wife Yasmeen  
And to my  
Lovely daughters Anam & Sanya

## ACKNOWLEDGMENT

It has been wonderful experience working with my supervisor Dr. Alex Domijan. We have been together for many years; successfully winning many competitive projects with me being the co-principle investigator. It is this joint effort and constant motivation of Dr. Domijan that today I am able to work towards Ph.D degree. I would like to thank my committee members, Dr. Huseyin Arslan, Dr. Thomas L. Crisman, Dr. James R. Mihelcic, and Dr. Stephen E. Sadow for their generous advice and interest. I would like to pass on my special thanks to Dr. Aleksandar Damnjanovic for his continuous support and direction for helping me complete my research work.

I would also like to thank the academic and administrative staff in the Department of Electrical Engineering and the Dean's office, where I am a regular with requests to manage various projects. I want to thank the wonderful researchers and professors at the Power Center for Utility Explorations (PCUE).

I would like to thank my siblings, who have given me every opportunity to work on my goals of gaining knowledge. I would like to give the heartiest thanks to my parents who have made countless sacrifices, and shown endless support to make me a successful man. None of this was possible without their endless support. I would like to thank my friends for all their support and advice.

Finally I would like to thank my unconditional supporter and endless motivator; my wife Yasmeen. She is my biggest critic; wanting me to be the best in my professional and personal life. Yasmeen is always there to motivate me during times of difficulty, when I have spent endless hours designing and developing various novel ideas with no view of the end results.

## TABLE OF CONTENTS

LIST OF TABLES .....	vi
LIST OF FIGURES .....	vii
LIST OF ACRONYMS AND ABBREVIATIONS .....	xi
ABSTRACT.....	xii
CHAPTER 1: INTRODUCTION.....	1
1.1 Background of the Study .....	1
1.2 Objective and Scope of the Research.....	6
1.3 Main Contributions .....	7
1.4 Outline of Dissertation.....	8
1.5 Publications Related to this Research.....	9
CHAPTER 2: SMART GRID: A MODERN POWER SYSTEMS .....	11
2.1 The Need to Overhaul Aging Grid Systems .....	11
2.2 Modern Power Systems and Smart Grids .....	13
2.3 Expectations from Modern Power Systems and Smart Grid .....	17
2.4 Smart Grid's Main Methodologies, Strategies, and Processes .....	18
2.4.1 Advanced Metering Infrastructure (AMI) .....	18
2.4.2 Home Area Network and New Products and Services .....	19
2.4.3 Distributed Generation.....	20
2.4.4 Plug-in Hybrid Electric Vehicles (PHEV).....	20
2.4.5 Transmission/Substation Automation.....	21

2.4.6 Distribution System Enhancements .....	21
2.4.7 Central Control Center .....	23
2.4.8 Cyber Security .....	24
2.4.9 Integration .....	25
2.4.10 Integration of Transmission/Substation Intelligence .....	29
CHAPTER 3: SMARTGRID RELIABILITY AND AVAILABILITY .....	31
3.1 Introduction to Smart Grid Power Quality, Reliability and Availability .....	31
3.1.1 Relationship of Power Quality, Reliability, and Availability .....	32
3.2 Power System Reliability, Availability Metrics, and Indices .....	34
3.2.1 Reliability .....	34
3.2.2 Availability .....	36
3.2.3 Reliability Indices .....	36
3.3 Interruption Causes and Modeling .....	37
3.3.1 Equipment Failure .....	37
3.3.1.1 Transformers .....	38
3.3.1.2 Underground Cables .....	40
3.3.1.3 Overhead Lines .....	41
3.3.1.4 Circuit Breakers .....	42
3.3.2 Weather Conditions .....	42
3.3.2.1 Wind .....	44
3.3.2.2 Ice Storms .....	47
3.3.2.3 Heat Storms .....	49
3.3.2.4 Rain .....	49

3.3.2.5 Lightning Strikes.....	52
3.3.2.6 Temperature .....	55
3.4 Optimization of Component Modeling.....	57
3.4.1 Area Under Study .....	58
3.4.2 Data Analysis and Processing.....	61
3.4.3 Combined Effects of Modeled Parameters .....	65
3.4.4 Design and Risk Assessment for a Predictor .....	70
CHAPTER 4: SMART GRID RELIABILITY PARAMETERS AND INDICES.....	77
4.1 Probability Distribution Functions.....	77
4.1.1 Normal Distribution Function.....	79
4.1.2 Exponential Distribution Function.....	79
4.2 Component Reliability Parameters .....	80
4.3 Component Reliability Data .....	81
4.3.1 Overhead and Underground Lines.....	81
4.3.2 Power Transformers.....	82
4.3.3 Power Generators.....	82
4.4 Smart Grid Reliability Indices .....	82
CHAPTER 5: NORMALIZATION OF RELIABILITY INDICES.....	85
5.1 Performance and Reliability Indices.....	85
5.2 Baseline Comparison and Other Methods .....	86
5.3 Assumptions and Statistical Tools .....	89
5.4 A Novel Method .....	91
5.5 Effectiveness of Results.....	101

5.6 Assessment and Limitations .....	105
CHAPTER 6: MODELING METHODS FOR SMART GRIDS .....	109
6.1 System Modeling and Analysis .....	110
6.1.1 Markov Modeling of Smart Grid .....	111
6.1.2 Modeling of the Smart Grid with a Boolean Logic Driven Markov Process (BDMP).....	114
6.1.3 Markov Modeling of Smart Grid Under Variable Weather Condition.....	117
7. SMART GRID MODELING AND ANALYSIS .....	120
7.1 System with Distributed Generator (DG) .....	121
7.1.1 System with no DG and no Influence of Weather .....	122
7.1.2 System with no DG and with Normal Weather Conditions.....	124
7.1.3 System with DG and No Influence of Weather .....	124
7.1.4 System with DG and Alternative Weather Conditions, Normal and Stormy Weather .....	126
7.2 System with Photovoltaic (PV) and Energy Storage System .....	130
7.2.1 System with no PV and Battery .....	132
7.2.2 System with PV and Energy Storage System and no Influence of Weather .....	132
7.2.3 System with PV and Energy Storage System, and Alternative Weather Conditions, Normal and Stormy Weather.....	135
7.3. System with Wind Generator and Energy Storage System .....	140
7.3.1 System with no Wind Generator and Energy Storage System (Battery)...	142
7.3.2 System with Wind Generator and no Influence of Weather .....	142



7.3.3 System with Wind Generator and Energy Storage System, and Alternative Weather Conditions Normal and Stormy Weather .....	145
CHAPTER 8: DISCUSSION, CONCLUSIONS, AND RECOMMENDATIONS FOR FURTHER RESEARCH .....	151
8.1 Discussions and Conclusions.....	151
8.2 Recommendations for Future Work.....	157
REFERENCES .....	159
APPENDICES .....	165
APPENDIX A: DEFINITIONS AND FORMULAE .....	166
ABOUT THE AUTHOR .....	172

## LIST OF TABLES

Table 3.1. Weather, Lightning and Interruption (N) Codes and their Explanations used for Combined Predictor Model.....	60
Table 3.2. P-values by Predictor and by MA [47] .....	67
Table 5.1. Location and Scale Factors .....	101
Table 5.2. Overall Improvements in rho.....	103
Table 5.3. Correlation Magnitude Characterizations .....	103

## LIST OF FIGURES

Figure 2.1. Trends for 55 Utilities Providing Data Between 2000-2005 (IEEE 2006) [17].....	12
Figure 2.2. Smart Grid Technologies and Benefits.....	13
Figure 2.3. Illustrating Renewable SEEDS with PHEV Load/Station Center.....	16
Figure 2.4. Top Level View of Interoperability: Smart Grid Systems .....	26
Figure 2.5. Smart Grid Coordination Across Generation, Transmission, and Distribution .....	29
Figure 3.1. Availability, Power Quality and Reliability Shown as Subsets of Each Other .....	34
Figure 3.2. Variation of Average N due to Transformer Failures Versus Maximum Temperature [45] .....	39
Figure 3.3. Distribution of Interruptions by Identifiable Causes .....	43
Figure 3.4. Variation of Mean of N Versus Wind in Dataset being Analyzed [47] .....	45
Figure 3.5. Variation of N Versus Wind.....	46
Figure 3.6. Mean of 2 minutes wind speed vs. average number of interruptions[47] .....	47
Figure 3.7. Monthly Mean Distribution of Rain for year 2000 [46].....	50
Figure 3.8. Monthly Mean Distribution of Rain for Year 2001 [46].....	50
Figure 3.9. Monthly Mean Distribution of Rain for Year 2002 [46].....	51
Figure 3.10. Monthly Mean Distribution of Rain for Year 2003 [46].....	51

Figure 3.11. Monthly Distribution of LS for year 2000 [46].....	53
Figure 3.12. Monthly Distribution of LS for year 2001 [46].....	53
Figure 3.13. Monthly Distribution of LS for Year 2002 [46].....	54
Figure 3.14. Monthly Distribution of LS for Year 2003 [46].....	54
Figure 3.15. Variation of Mean N Versus Average Temperature [47].....	56
Figure 3.16. Location of Weather Data Recorder.....	59
Figure 3.17. Sample List of Key Data(row) for Modeling a Combined Predictor .....	63
Figure 3.18. R2 Values of Modeled Versus Raw Weather Data by MA and by Weather Parameter [47] .....	66
Figure 3.19. R2 Values of Modeled Versus Raw Weather Data by MA [47] .....	66
Figure 3.20. Percentage of Occurrences of Average Temperature for Combined Datasets [47] .....	68
Figure 3.21. R2 Values of Five Regions.....	71
Figure 3.22. Predictor Value vs Actual N for multiple MAs.....	72
Figure 3.23. Actual and Predicted Numbers of Interruptions.....	73
Figure 3.24. Neural Network Function Approximation.....	74
Figure 5.1. Mean of N by Month and Year.....	87
Figure 5.2. Mean of LS by Month and Year.....	87
Figure 5.3. Mean of Rain by Month and Year.....	88
Figure 5.4. Confidence Intervals as a Function of n and $\rho$ .....	91
Figure 5.5. Probability Plot of 2MMaxS Data.....	95
Figure 5.6. Histogram of 2003 Standardized 2MMaxS Data .....	97
Figure 5.7. Histogram of 2003 2MMaxS Data Standardized with 2002 Location	

and Scale Factors .....	97
Figure 5.8. Histogram of Rain .....	98
Figure 5.9. Histogram of LS .....	98
Figure 5.10. Pre and Post Adjustment $\rho$ by MA for 4 Years Daily N with 95% Confidence Intervals .....	101
Figure 5.11. Pre and Post Adjustment $\rho$ by MA for 4 Years Daily CI with 95% Confidence Intervals .....	102
Figure 5.12. Pre and Post Adjustment $\rho$ by MA for 4 Years Daily CMI with 95% Confidence Intervals .....	102
Figure 5.13. Pre and Post Adjustment $\rho$ by MA for SAIFI for 46 months with 95% Confidence Intervals .....	104
Figure 6.1. BDMP with one Trigger .....	116
Figure 6.2. Standby System .....	116
Figure 6.3. BDMP Representation of the System in Figure 6.2 .....	116
Figure 6.4. Markov model representation of the system in Figure 6.2 –State Space Diagram.....	117
Figure 6.5. Single Unit State Space Diagram .....	118
Figure 7.1. Smart Grid Single Line Diagram.....	120
Figure 7.2. System with Distribution Generator (DG) Single Line Diagram.....	122
Figure 7.3. State Space Diagram for System with no DG no Weather Conditions .....	123
Figure 7.4. State Space Diagram for System with DG No Weather Conditions .....	125
Figure 7.5. State Space Diagram for System with DG and Alternative Weather Conditions, Normal, and Stormy Weather.....	128

Figure 7.6. System with PV and Energy Storage System (B), Single Line Diagram.....	132
Figure 7.7. State Space Diagram for System with PV and Energy Storage System No Weather Conditions .....	133
Figure 7.8. State Space Diagram for System with PV and Energy Storage System and Alternative Weather Conditions, Normal, and Stormy Weather .....	137
Figure 7.9. System with Wind Generator (Wg) and Energy Storage System (B), Single Line Diagram .....	142
Figure 7.10. State Space Diagram for System with Wg and Energy Storage System no Weather Conditions .....	143
Figure 7.11. State Space Diagram for System with PV and Energy Storage System and Alternative Weather Conditions, Normal, and Stormy Weather .....	147

## LIST OF ACRONYMS AND ABBREVIATIONS

- AESS- advance energy storage system  
AMI-advanced metering infrastructure  
AMR-automated meter reading  
AMS-advanced metering system  
ASOS-Automated Surface Observation Stations  
BDMP- Boolean Logic Driven Markov Process  
CA-Control Area  
CAIDI-Customer Average Interruption Duration Index  
CBL-customer baseline load  
CHP-combined heat and power  
CIP-critical infrastructure protection  
CI Confidence Interval  
CPP-critical peak pricing  
CPUC-California Public Utilities Commission  
CMI Customer Minutes Interrupted  
EPRI- Electric Power Research Corporation  
EPDIRAC® - Electric Power Distribution Risk Assessment Calculator (A patent product of USF)  
MA- Management Area (geographic region)  
N- Number of interruption  
SAIFI-Systems Average Interruption Frequency Index  
SAIDI- System Average Interruption Duration Index  
SEEDS- Sustainable Electrical Energy Delivery System  
NIST- National Institute of Standards and Technology

# **SMART GRID RELIABILITY ASESMENT UNDER VARIABLE WEATHER CONDITIONS**

**Arif Islam**

## **ABSTRACT**

The needs of contemporary electric utility customers and expectations regarding energy supply require dramatic changes in the way energy is transmitted and delivered. A smart grid is a concept by which the existing and aging electrical grid infrastructure is being upgraded with integration of multiple applications and technologies; such as two way power transfer, two way communication, renewable distributed generation, automated sensors, automated & advanced controls, central control, forecasting system and microgrids. This enables the grid to be more secure, reliable, efficient, self-healing, while reducing greenhouse gases. In addition, it will provide new products & services and fully optimize asset utilization. Also, integration of these innovative technologies to establish a smart grid poses new challenges.

There will be need for new tools to assess and predict reliability issues. The goal of this research is both to demonstrate these new electrical system tools and to monitor and analyze the relationship of weather and electrical infrastructure interruptions. This goal will be accomplished by modeling weather and distribution system reliability issues, by developing forecasting tools and finally developing mathematical models for system



availability with smart grid functionality. Expected results include the ability to predict and determine the number of interruptions in a defined region; a novel method for calculating a smart grid system's availability; a novel method for normalizing reliability indices; and to determine manpower needs, inventory needs, and fast restoration strategies.

The reliability of modern power distribution systems is dependent on many variables such as load capacity, renewable distributed generation, customer base, maintenance, age, and type of equipment. This research effort attempts to study these areas and in the process, has developed novel models and methods to calculate and predict the reliability of a smart grid distribution system. A smart grid system, along with variable weather conditions, poses new challenges to existing grid systems in terms of reliability, grid hardening, and security.

The modern grid is comprised of various distributed generation systems. New methods are required to understand and calculate availability of a smart grid system. One such effort is demonstrated in this research. The method that was developed for modeling smart grid dynamic reconfigurations under variable weather conditions combines three modeling techniques: Markov modeling, Boolean Logic Driven Markov Process (BDMP) and the modeling of variable weather condition. This approach has advantages over conventional models because it allows complex dynamic models to be defined, while maintaining its easy readability.

## CHAPTER 1: INTRODUCTION

### 1.1 Background of the Study

A smart grid modernizes electrical transmission and distribution networks to provide customers with dual-direction electricity that is secure, reliable, distributed and has reduced emissions. Smart grids use two-way communications, advanced controls, modern sensors, and micro-grids in conjunction with central station generation and distributed networking servers/computers to improve efficiency, reliability and safety of power delivery as well as prudent use of energy. Smart Grid is also referred to as Smart Power Grid, Smart Electric Grid, Intelligrid, and FutureGrid.

Electrical power systems include a network of power plants, power lines, substations, distribution lines and consumers. The next generation of power system smart grid will be achieved when a variety of important technologies, including smart meters, electronic sensors, electronic controls, renewable energy sources and energy storage elements are incorporated into one system that will afford automatically correct power supply variability; distribute clean generation and storage; and maintain system reliability at all times under all conditions. The benefit of a smart grid is that it provides an instantaneously, accurate flow of information, eliminating cumbersome layers of tedious manual decision-making by system operators. Instead, a smart grid automates the complex network of devices that control flow of electricity to work together faster, more

efficiently and with a level of precision that is not possible using manually operated systems.

The effects of weather, from heat waves to hurricanes, on the electrical infrastructure are expected to escalate world-wide. Associated power interruptions create economic hardships of several billion dollars annually on the state and its citizens, while also posing a significant threat to public safety. The economic impact and threat to public safety will surely escalate as the population increases, resulting in a steadily increasing demand on electrical infrastructure. Consequently, electrical infrastructure is fragile; as each adverse weather system passes over the state, supplying energy and restoring service becomes more difficult. Electrical infrastructure is considered to be the most complex system ever developed by mankind, and it will take decades to update. An energy plan that incorporates a diversified portfolio of generation sources, from central-station to renewable and distributed, will not become reality if electrical infrastructure is not appropriately developed in conjunction with energy supply.

Smart grid will allow the current electricity system to incorporate better renewable energy sources such as wind and solar power. The benefits of a smart grid include increased efficiency of the current electrical infrastructure, reduced greenhouse gas emissions, and reduced consumer costs. Successfully incorporating renewable electricity sources into existing power transmission and distribution systems requires wide-area deployment of smart grid technology. The goal of a smart grid system will be to optimize supply and delivery of electrical energy, minimize losses, “self heal”, enable maximum use of renewable energy resources and substantially increase energy efficiency.

It will also improve penetration of renewable distributed generation into the grid system since it has a faster response to intermittent power and keeps electricity supply in absolute balance with consumer demand at all times. As a result, far less storage capacity will be required to keep the power system from failing. In addition, a smart grid can protect users when renewable sources are not operating at optimal generation. It also will enable each transmission and distribution line to carry much more electricity without risk of overloads and blackouts during high generation periods. Finally, a smart grid will enable consumers to control the cost and quality of their electricity service better with absolute convenience.

Smart grid engineering is divided into planning and design stages. The planning stage is to identify system needs and limitations, propose projects, resolve issues and obtain project approvals. The design stage takes a project from concept to final realization. Smart grid technologies are expected to change fundamental design and operating requirements of the electric power system. The primary engineering tools for Smart grid analysis and design are power flow and fault-current studies. A power flow analysis computes steady state voltages and currents of the systems, ensuring that the system will meet criteria of equipment loading, voltage drops and system losses. While power flow modeling can predict electrical properties of the smart grid, reliability modeling predicts the system's availability and interruption. Reiterating, a smart grid will allow current power electrical systems to incorporate better renewable energy sources such as wind and solar power, back-up distribution generators and energy storage systems.

Dependability of the smart grid is one of the most important areas of reliability theory application. Random failures are certain to occur from time to time, especially when weather extremes or other causes present hazards that the power system was not designed to withstand. Reliability methods provide important analytical tools that can be used to evaluate and compare smart grid design and performance. Each component has its unique characteristic. Models should be as simple as possible, but they need to represent all features critical to system reliability. Reliability parameters vary from component to component or from situation to situation. Component reliability data are one of the most important parameters of smart grid reliability assessment. Smart grid reliability information is based on historical utility data and manufacturer test data, as well as technical conferences and peer reviewed literature such as IEEE, International Journal of Power and Energy Systems and Cigre .Electrical equipment reliability data usually are obtained from surveys of individual industrial equipment failure reports. Collection of reliability data are a continual process; data is constantly updated.

Reliability of power distribution systems is dependent on many variables such as load capacity, customer base and maintenance, as well as age and type of equipment. However, the variable most often responsible for degraded reliability is weather, and common weather conditions often are overlooked in reliability analyses. These conditions include, but are not limited to, rain, wind, temperature, lightning, humidity, barometric pressure, snow and ice.

During an interruption, customers within a community are able to intentionally island, thus reconfiguring total loads to only critical loads while meeting critical loads by managing renewable energy sources and the energy storage system. One objective of this

study is to evaluate reliability improvement associated with this optimal structure of the power system. Enhancement in reliability will be quantified in terms of proposed new reliability indices that are pertinent to commercial-residential communities that contain renewable energy systems along with energy storage systems.

Common weather does not include catastrophic events such as hurricanes or tornados “which exceed reasonable design or operational limits of the electric power system” [1], and for which there are methods in place, or being studied, to define major reliability events, including weather events, and excluding the consequent interruptions from the calculation of reliability indices [2, 3, 4].

Much of the focus of modeling the effects of weather on power distribution systems has remained fixated on extreme weather conditions [5, 6, 7]. A body of work including weather as a factor in the analysis of specific fault causes also exists [8-13]. However, models that use the combined effects of common weather conditions to predict the total number of daily or by-shift interruptions are presently not available.

There is a need for methods that can predict daily or by shift power distribution system interruptions based on common weather conditions, and for interruption risk assessment based on immediate weather conditions. A related method of normalizing reliability indices for common weather conditions also is needed to improve reliability assessments of power distribution systems.

Dynamic reconfigurations of the smart grid and variable weather conditions create difficulties in reliability modeling and analysis. To overcome these obstacle, a method combining three modeling techniques has been developed. The techniques include: Markov modeling, Boolean Logic Driven Markov Process (BDMP) and Modeling of

variable weather conditions. This modeling approach enjoys advantages over conventional models because it allows complex dynamic models to be defined while remaining easily readable.

## **1.2 Objective and Scope of the Research**

Reliability analysis is stochastic and predictive in nature. The goal of a distribution system reliability tool must be to provide consistent, accurate comparisons between competing design options. In this effort, conduct unique research to find out the effects of smart grid infrastructure and variable weather conditions over the reliability of a smart grid. A mathematical concept/tool would be utilized to scientifically obtain results and develop conclusions and recommendations for future work. The research has importance because, at present, worldwide investments are taking place both to modernize grids and to bring smart grid technologies to grids hoping that there will be improvement in reliability in terms of failures of the system.

The main objective of this research is to develop models and methods for smart grid reliability assessment under variable weather conditions. Applying different reliability modeling techniques and approaches to solve the present obstacles for smart grid reliability modeling and calculations:

- Based on common weather conditions, a theoretical model can be used for the prediction of power distribution interruptions and for interruption risk assessment based on immediate weather conditions. Using daily and hourly weather data, these models will be used to predict the number of daily or by shift interruptions and to normalize the reliability indices for weather.

- The method for normalizing reliability indices for common weather conditions has been developed. Power companies are constantly striving to improve their reliability performance and one method commonly used to identify changes in performance is a comparison of present performance with past performance. Such methods are often not accurate due to changing weather conditions which can skew the figures used for comparison. The present method diminishes the impact of common weather conditions and makes comparisons that allow for a more accurate determination of reliability performance.
- Model dynamic reconfigurations of the smart grid under variable weather condition combining modeling techniques: Markov modeling, Boolean Logic Driven Markov Process (BDMP) and Modeling of variable weather condition.

### **1.3 Main Contributions**

The main contributions made by this research are the development and application of original models and methods for reliability assessments of smart grids under variable weather conditions:

- Method for modeling smart grid dynamic reconfigurations under variable weather conditions combining the aforementioned three modeling techniques( Markov modeling, Boolean Logic Driven Markov Process (BDMP) and the modeling of variable weather conditions).
- Developed a method of predicting power distribution interruptions in a given region based on common weather conditions and assessing the risk of interruptions on immediate weather conditions. Using daily and hourly weather data, the method predicts the number of daily or by shift interruptions.



- Developed is the method for normalizing reliability indices for common weather conditions. The methods commonly used are based on changes and comparison of present and past performance. The developed method diminishes the impact of variable weather conditions and makes comparisons that allow for a more accurate determination of reliability performance.
- The predictor method that will reduce the downtime of power interruptions by proper distribution of the service work force is developed. The model offers an economical tool with negligible maintenance costs to utilities, and improves its Systems Average Interruption Frequency Index (SAIFI) while increasing its power transmission.
- The research improves reliability assessments by using hourly (or half-hourly) weather data, and reorganizing the interruption data that are reported by substations into datasets that are geographically centered on ASOSs.

#### **1.4 Outline of Dissertation**

This dissertation is divided into eight chapters. Chapter 1 is the introduction and explanation of the study objective. Chapter 2 is an introduction to the smart grid. This chapter introduces the important technologies being brought to electricity grid infrastructure to improve efficiency and reliability. Since modernization of the electrical grid is taking place as this document is written, the studies done over such a novel system are still unique. Chapter 3 documents in detail the research effort to model various weather parameters affecting the reliability of modern distributed systems. It provides the design of the models on which the predictor will predict the number of interruptions (N) in an area. It starts with the modeling of effects of individual weather

parameters, then slowly builds the combined effect model. Chapter 4 introduces typical tools used in smart grid reliability evaluation: Probability Distribution Functions, Component Reliability Parameters, Component Reliability Data, and Smart Grid Reliability Indices. Chapter 5 develops and documents a novel method to normalize reliability indices for common weather conditions. Chapter 6 is a brief introduction modeling methods of smart grid and the modeling techniques used in this research. Chapter 7 is a practical application of the proposed method on different smart grid configurations including: system with a distribution generator, system with a photovoltaic source and energy storage, system with wind generator and energy storage under variable weather conditions. Chapter 8 draws conclusions and proposes future research efforts.

### **1.5 Publications Related to this Research**

The following section provides a list of publications submitted, published and presentations made related to the topic of research:

- “Electric Power Distribution System Reliability Modeling and Risk Assessment”, A. Islam, A. Domijan Jr., W.S. Wilcox, IEEE Transactions on Power Delivery, 2010
- “Statistical Normalization of Reliability Indices for Common Weather Conditions”, A. Islam, A. Domijan, W. S. Wilcox, IEEE Transactions on Power Systems, 2010
- “Reliability Evaluation Method for a Dynamic Smart Grid System”, A. Islam, A. Domijan, Jr., A. Damnjanovic, International Journal of Power & Energy Systems, 2010

- “Smart Grid Reliability Assessment”, A. Islam, A. Damnjanovic, A. Domijan, Jr., PES conference, International Association of Science and Technology for Development (IASTED), 2010
- “Price Responsive customer screening using load curve with inverted price tier”, A. Domijan Jr., A. Islam., M. Islam, A. Miranda, A. Omole, H. Algarra, TECO load research and forecasting team, International Journal of Power & Energy Systems, 2010
- “Weather & Reliability”, A. Islam, A. Domijan, Jr., 2007 PES General Meeting, IEEE Power Engineering Society.
- “Modeling the Effect of Weather Parameters on Power Distribution Interruptions”, A. Domijan, Jr., A. Islam, W.S. Wilcox, R.K. Matavalam, J.R. Diaz, L. Davis, and J. D'Agostini, presented & published(ISBN 0-88986-449-7) at the 7th IASTED Int. Conf. Power and Energy Systems, Clearwater Beach, FL, USA, Nov. 2004
- Panelist for Electricity Grid Infrastructure Research—Current and Future Developments at 2007 IEEE PES conference Tampa FL USA
- Paper presentation at 2007 IEEE PES conference Tampa FL USA
- Chaired a session “SESSION 11 – Power System Control And Operations”, Chairs: A. Islam (USA) and M. Paloranta (Finland) at 7th IASTED Int. Conf. Power and Energy Systems, Clearwater Beach, 1, USA, Nov. 2004
- Posters at UF & USF

## **CHAPTER 2: SMART GRID: MODERN POWER SYSTEMS**

In order to meet contemporary needs of consumers, changes have to be made in production, distribution, and consumption of electricity. The utility industry is one of the largest industrial sectors in the field of technology. In the United States, it has a combined asset exceeding trillions of dollars. There are more than 3,273 utilities in the United States, providing electricity to over 131 million customers [14]. The primary goal of these utilities is to provide reliable and efficient electricity to consumers. Even with the highest quality of utility services, direct and indirect losses attributed to power interruptions are tremendous.

### **2.1 The Need to Overhaul Aging Grid Systems**

The national cost of power interruptions is approximately 80 billion dollars annually [15]. In the last 40 years, hundreds of blackouts have occurred in the United States, with the majority occurring in the last 15 years. The main cause of such massive failures is attributed to the use of archaic mechanical systems, which cannot accommodate modern heavy demands for power. Moreover, by improving the efficiency of the grid by a mere 5%, emissions can be reduced by an amount that equates to taking 53 million cars off the road [16]. Reliability indices such as System Average Interruption Frequency Index (SAIFI), System Average Interruption Duration Index (SAIDI) and Cumulative Average Interruption Duration Index (CAIDI) have all increased in the last decade. SAIDI has increased by more than 20% for the 55 utilities that data were made available to from the department of energy, as shown in figure 2.1.

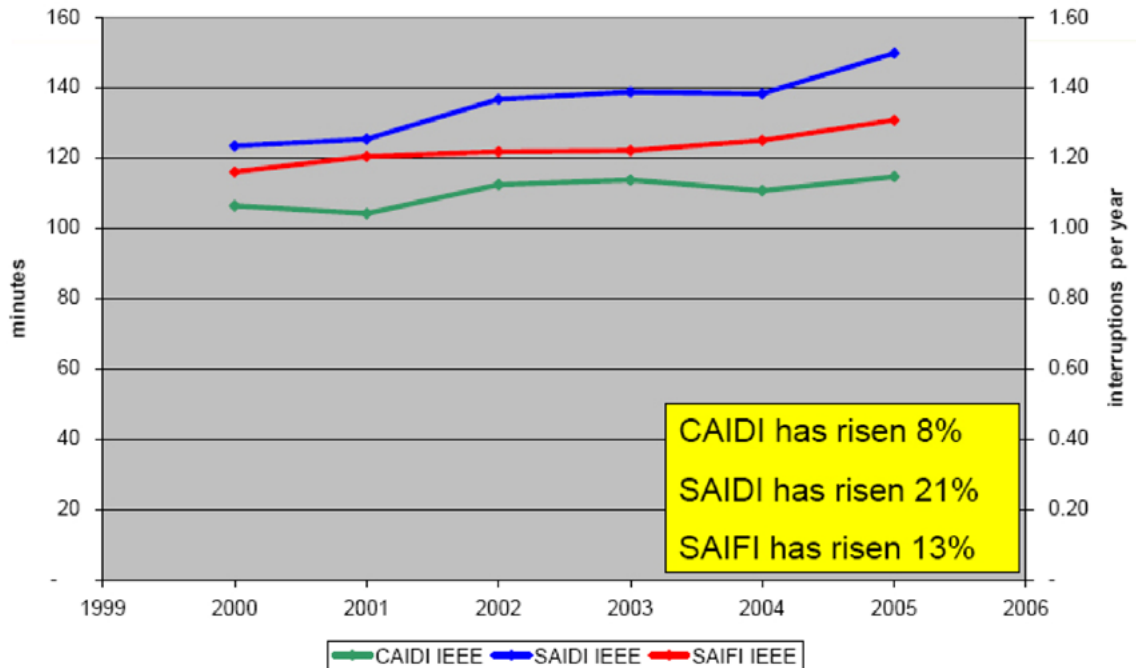

Figure 2.1. Trends for 55 Utilities Providing Data Between 2000-2005 (IEEE 2006) [17]

In order to respond to increasing demand for electricity and harmful effects of greenhouse gases, the current grid system needs to be upgraded. Funding is crucial in implementing such large scale changes in the grid system. The power industry is very significant in the United States economy. It is one of the largest and most capital-intensive sectors in the U.S. economy, 60% of which is invested in power plants, 30% in distribution facilities, and 10% in transmission facilities. In order to maintain America's global competitiveness, electric power needs to be reliable.

In the past 4 or 5 decades, no significant changes occurred in overall infrastructure of the transmission and distribution system of electricity. Recently, the US government started developing various programs. The goals of these programs are to provide everyone access to abundant, affordable, clean, efficient, and reliable electric power anytime and anywhere.

## 2.2 Modern Power Systems and Smart Grids

Smart grid is a modern electrical transmission and distribution network system that provides customers secure and reliable electricity. The advantages of smart grids are: two-way communications, advanced controls, modern sensors, micro-grids, and central station generation, which improve the efficiency, reliability, and safety of power delivery. Smart grid is also referred to as "Smart Power Grid," "Smart Electric Grid," "Intelligrid," "FutureGrid," and FRIENDS (Flexible Reliable Intelligent Energy Delivery System).



Figure 2.2. Smart Grid Technologies and Benefits

The smart grid is an integration of many technologies that modernize the electrical grid infrastructure. Major areas and technologies are Advanced Metering

Infrastructure, distributed renewable generation, predictive and central control (diagnostic center), demand side management and bi-directional flow of energy. Modernization of power systems can be achieved by integration of renewable and other distributed energy generation systems. This results in advanced sensors, communication and control technologies, monitoring, diagnostic and automation capabilities, and two-way communication between the utility and electric loads. Benefits of such implementations are that these technologies provide improved grid reliability & efficiency, increased security and power quality, reduce restoration time, new products and services to customers, optimization of asset utilization, and improved energy security. In a situation where there is an outage at the feeder level, the full capability of the grid can be utilized by integration of Distributed Generation (DG) in a smart grid, Demand Response, VAR control, and Distribution Automation. Other key benefits include achieving increased customer reliability under system contingencies and outage conditions without additional feeder construction, and demonstrating the opportunity to revolutionize distribution systems globally through the integration of technologies. The distribution system is expected to be flexible and responsive to system contingencies, such as peak loading due to weather, loss of generation capacity, equipment failures, and natural disasters.

Utilities have excess power generating capabilities during off-peak hours when consumers are utilizing less energy. Two sites were developed in St. Petersburg, Florida to test the modern storage systems with live connectivity to the grid and power generation via solar panels. The site is called SEEDS (Sustainable Electric Energy Delivery Systems). The renewable SEEDS project uses excess energy to charge a 5KW Advanced Energy Storage System (AESS). AESS is a battery system with modern communication

features and grants users control over the rate of charging and discharging, which allows storage of energy for future use. It is expected that car users would charge their PHEV at off peak times for the grid. This would require additional informational flow to electric consumers about OFF and ON peak demand times and duration.

The Renewable SEEDS project has solutions for these issues. The Renewable SEEDS site(s) can act as modern power stations to charge PHEV anytime. The site uses the excess off peak energy to charge already installed 5 KW AESS. In addition, during peak daytime hours, there is a 2KW solar panel (possible expansion to 5KW) which charges the battery. The excess energy will then be stored for future use for PHEV's. The results of SEEDS demonstrated that the peak load shaving is possible by storing the intermittent renewable energy into AESS and delivering it at the peak power requirement, which is typically in the afternoon for the summer and early morning in the winters in the south Florida region.



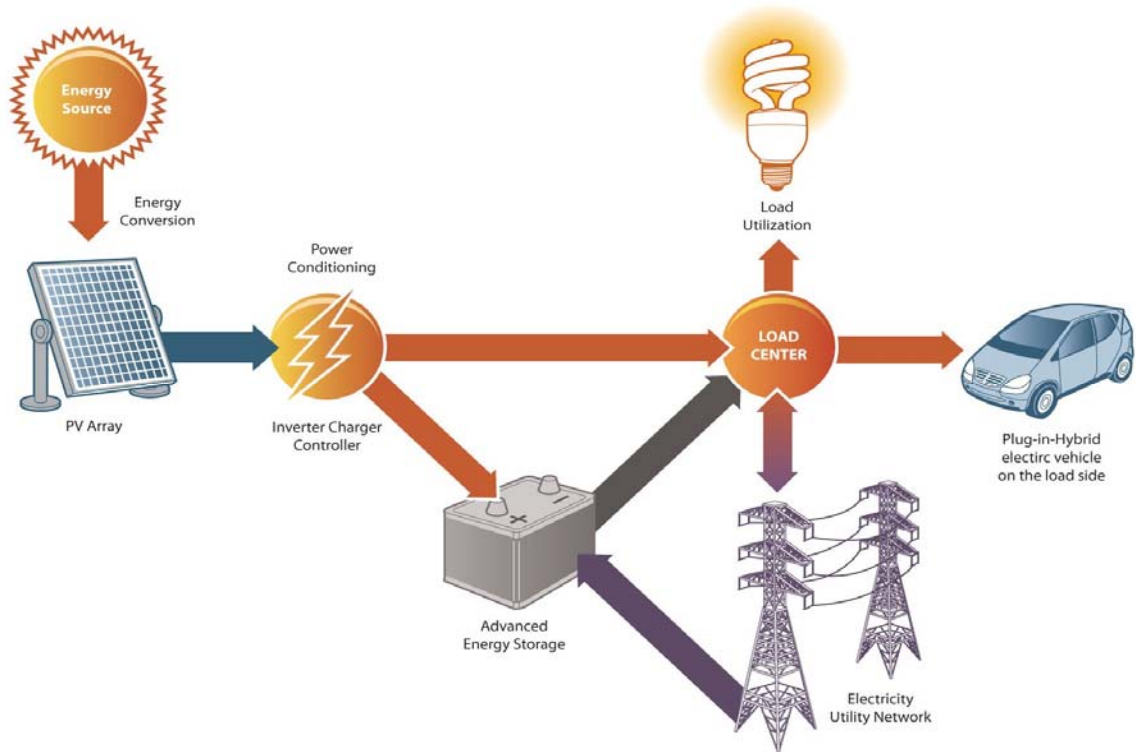

Figure 2.3. Illustrating Renewable SEEDS with PHEV Load/Station Center

With introduction of distributed generations and two way power flow; complexity of the systems involved increases enormously. Methods to assess reliability and have some kind of predictive system are necessary. The smart grid has the capability to respond to these issues. The unpredictability of the system can be improved by implementing a predictive system across the electrical distribution system. Smart grid can improve reliability, predict interruptions, reduce down times, maximize resource management, and assist in self-healing of the network. Submitted in this document is a novel model (patent of USF) that implements this system.

Effects of weather (e.g. rain, heat waves, hurricanes) on the electrical infrastructure are expected to escalate globally. Power interruptions are economic

hardships that cost several billion dollars annually. The current electrical infrastructure does not have the capacity to control the effects of power interruptions.

### **2.3 Expectations from Modern Power Systems and Smart Grid**

Despite the large amount of time spent in selecting various technologies for smart grids, the main goal of providing wealth to customers and investors should not be neglected. Continuous updates and feedback from customers are necessary. The main point is that the utility industry is full of experts who know instruments and products, but the consumer angle is often lost. Understanding customer's needs and requirements is important to appreciate efforts put into implementing a complex system such as the smart grid.

An important challenge for the utility industry is to endure declining growth. The utility industry is high in capital investment; thus, opportunities for grid electrification need to be maximized. With advent of modern PHEVs (Plug in Hybrid Electric Vehicle), opportunities are present to develop interfacing and billing systems that charge PHEV at every home in the country. Another interesting opportunity is to develop modern/smart appliances for modern grid system. Expectations from smart grid are to:

- Provide new products, services, and markets.
- Optimize asset utilization and operate efficiently.
- Predict and respond to system disturbances (self-heal)
- Be rugged against man-made and natural disasters.
- Address modern customer expectations.
- Involve active participation from the customer.

- Make available bi-directional, reliable, and environmentally friendly power for needs of the 21st century (nano/digital economy).
- Involve all generation, transmission, distribution, and storage options.

The challenges associated with these expectations are:

- One of the main results expected from smart grid implementation is the fulfillment of modern day customer needs, which is to maximize stakeholders wealth.
- Focus was initially not on customers due to hardware and technology concerns in initial stages of system implementation.
- Trend of declining growth, maximizes opportunities of grid electrifications.
- Develop modern/smart appliances for modern grid system: the last mile solutions

#### 2.4 Smart Grid's Main Methodologies, Strategies, and Processes

Smart grid is an integration of multiple technologies, methodologies, and processes, layered and combined together to provide efficient, reliable, secure power and user friendly interface to consumers. Smart grid technologies can be divided into major areas: Advanced Metering Infrastructure, Home Area Network, Distributed Generation, Plug-in Hybrid Electric Vehicles, Transmission/Substation , Distribution System Enhancements, Central Control Center, and Cyber Security. Following section provides an overview of these technologies.

##### **2.4.1 Advanced Metering Infrastructure (AMI)**

The overall objective of Advanced Metering Initiative is to provide a foundational communication platform that is robust, reliable, and secure. This platform can then be utilized to provide full 2-way communications to field devices including meters, devices

in customer's homes, distribution system assets, and other applications [18]. Deployment of AMI in service territory focuses on collecting and providing data for every meter in the service area. AMI deployment includes foundational meter deployment and aspects to fully test the inclusion of in-home devices. AMI will create a base platform through a replicable model that demonstrates and quantifies benefits of smart grid deployment. With AMI in place, there will be quantifiable results of its impact on consumer energy usage and conservation. Included are: new rate and pricing options, utility system reliability and power quality, optimization of asset utilization and operating efficiencies, system disturbances and the ability for self-healing, and resilience against physical and cyber attacks. Installation of AMI is the first step required to enable other aspects of smart grids to be fulfilled.

#### **2.4.2 Home Area Network and New Products and Services**

The Home Area Network (HAN) provides customers with tools, technologies, and billing rates in the conservation effort of energy consumption [19, 20]. Until now, energy is consumed before the customer knows what the total monthly charges are. Advance notice of expected energy consumption and possible cost empowers customers to make informed decisions and actions regarding their energy usage at own home. Various demand side management concepts are attempted to harness the benefits of smart grid technology [21]. This will drive significant economic benefits to all customers through decreased energy bills. A parallel effort is ongoing to develop home appliances and other items that can easily communicate with AMI meters. This would enable control of such appliances from remote locations, and along with the help of advance communication setups, consumers will have better control over energy expenditure.

### **2.4.3 Distributed Generation**

The past decade has seen an enormous increase in the number of distributed generation resources. Most of these resources work in isolation and have no or very limited connectivity with the electric grid. With advent of smart grid technologies, these distributed resources can be brought onto the grid, thus reducing capital investment to build more power plants and avoiding creation of more green house gases. Integration of distributed generation technology onto the grid [22, 23] will enable renewable generation to interact with the electric grid, specifically for power generation, power quality, reliability, and customer interaction. This also helps quantify environmental benefits of renewable energy generators. Renewable generation will create and support more jobs in the “green” technology field. This area analyzes the following:

- Advanced grid planning and operations needed for large-scale integration of distributed renewable systems into the distribution system.
- Impact of high-penetration renewable generation such as photovoltaics on the utility grid.
- Voltage regulation issues caused by the interconnection of various penetration levels of renewable generation on the distribution system.
- Energy storage (batteries) and controls systems.

### **2.4.4 Plug-in Hybrid Electric Vehicles (PHEV)**

PHEV provides tremendous benefits in reducing carbon emissions, since power plants are relatively more efficient than individual cars working on mechanical engines. Technologies are ready for implementations, wherein the consumer can charge the electric vehicle at home. Various efforts are ongoing to establish stations for charging

such vehicles [24]. The SEEDS project (described earlier in this chapter) is one such projects where the PHEV vehicle can be charged at higher speed if it is capable of accepting a higher rate of current. This reduces charging time. Implementation of PHEV technology provides another means of service from the utility to its consumers.

#### **2.4.5 Transmission/Substation Automation**

Implementation of the Smart Grid Reliability System will provide better utilization and reliability of the overall electric grid, with reduction of greenhouse gas emissions and an increase in system capacity. By installing field monitoring instrumentation devices to gather real-time telemetry information [25], the following benefits can be provided:

- Reduce duration of customer service interruptions through accurate outage detection and feeder automation.
- Prevent future outages by performing predictive reliability analysis.
- Reduce system losses, thereby reducing energy use and carbon emissions.
- Increase agility to manage grid load across Transmission and Generation, and more effectively optimize system capacity.
- Support integration of local storage, distributed generation, and hybrid electric vehicles.
- Effectively dispatch power generation resources based on optimal combination of cost, emissions, fuel, and other future environmental constraints.

#### **2.4.6 Distribution System Enhancements**

The system will benefit from the communications infrastructure of AMI [5 enhancing power] and also by inclusion of self-healing automation and remote

monitoring of the distribution components. These improvements will enhance daily operations of grids including reliability of electric services. This is accomplished through the following installations:

- Automated Feeder Switches (AFS), which have capability to work in coordination with the feeder breaker to detect faults on the distribution system, isolate the faulted section, and restore service to unaffected line sections.
- Two-Way Capacitor Controls on feeders to work in coordination with existing Distribution Management System (DMS) to optimize reactive power of the system. This will reduce energy losses on the distribution system. Today, most grids utilize a one-way radio system to issue control commands to pole-top capacitor banks. Confirmation cannot be made if the control has been executed. This often requires multiple control commands being issued to a capacitor bank. This causes delays in achieving the desired level of reactive power. Implementing the two-way communications will provide confirmation of control commands that are executed.
- Monitoring equipment on automatic “Throw-over” switches to communicate status to operators in Distribution Control Center. This will identify any switches that have not operated properly so a field technician can be dispatched quicker to restore service.
- Voltage and current sensors on distribution feeders that can provide real-time inputs to enhance power-flow analysis performed by DMS and to provide inputs to predictive models. This will improve operation network analysis functions,

utilized for performing switching on the distribution system to prevent overloaded equipment conditions as well as optimizing voltage.

- Remote fault indicators at strategic locations on distribution feeders that can be used in conjunction with fault locating capabilities of DMS to detect the location of faults in the distribution system. This will enable faster restoration for sustained interruptions and assist in investigation of momentary interruptions.

#### **2.4.7 Central Control Center**

The intent of the Smart Grid Reliability System is to design and deploy an advanced Central Controls center, which includes an investment in a modernized Energy Management System and Intelligent Electronic Devices (IED's) to achieve maximum value from smart grid telemetry [27,28]. This system creates a predictive overall view of generation, transmission, distribution, and customer device data to improve grid performance, increase reliability, and reduce outage restoration times. In addition to driving efficiencies, it will provide the capability to model impacts of hybrid electric vehicles and distributed renewables such as wind and rooftop solar. Prudent investments in measurement devices and system analytics will support regulatory requirements, drive increased system reliability, and meet critical cyber security mandates. Implementation of the enterprise wide Smart Grid Central Controls Center includes:

- Develop an Enterprise Wide Smart Grid Central Controls Center to incorporate data from Customer, Distribution, Transmission, and Generation systems for a more comprehensive visualization of grid functions.



- Develop advanced applications and analytics to provide a predictive overall view of data to improve grid performance, increase reliability, and reduce outage restoration times.

- Manage reliability and risk profile of energy delivery across the enterprise.

Better utilization and reliability to the overall electric grid, reduction in greenhouse gas emissions, and increased system capacity are the anticipated benefits of the Smart Grid Reliability System. By installing field monitoring instrumentation devices to gather real-time telemetry information, the system will be able to provide the following benefits:

- Reduce duration of customer service interruptions through accurate outage detection and feeder automation.
- Ability to prevent future outages by performing predictive reliability analyses.
- Reduce system losses, thereby reducing energy use and carbon emissions.
- Increase agility to manage grid load across Transmission and Generation, which more effectively optimizes system capacity.
- Support integration of local storage, distributed generation, and hybrid electric vehicles.
- Effective dispatch of power generation resources based on the optimal combination of cost, emissions, fuel, and other future environmental constraints.

#### **2.4.8 Cyber Security**

Cyber security is a critical component in implementation of smart grids because grids that have been working in isolation will become connected to modern communication systems, including wireless networks. This makes the system prone to

cyber attacks [29]. Cyber security is a vast research area in itself; the topic will not be discussed further because it is not the focus of this research.

#### **2.4.9 Integration**

One of the biggest challenges faced by the power engineering community is how to integrate all these technologies so that interoperability is established as per expectations [30]. One of the biggest efforts in interoperability has been done by the team of EPRI/NIST (Electric Power Research Institute/National Institute of Standards and Technology). Interoperability Framework is emerging as a norm for key devices and systems [31]. This clearly defines interface points among business domains, systems, and smart grid components. The following is a subset of a high level view based on EPRI/NIST suggested standards.(figure 2.4). A similar effort is also promoted by GridWise Architectural Council Interoperability Framework.

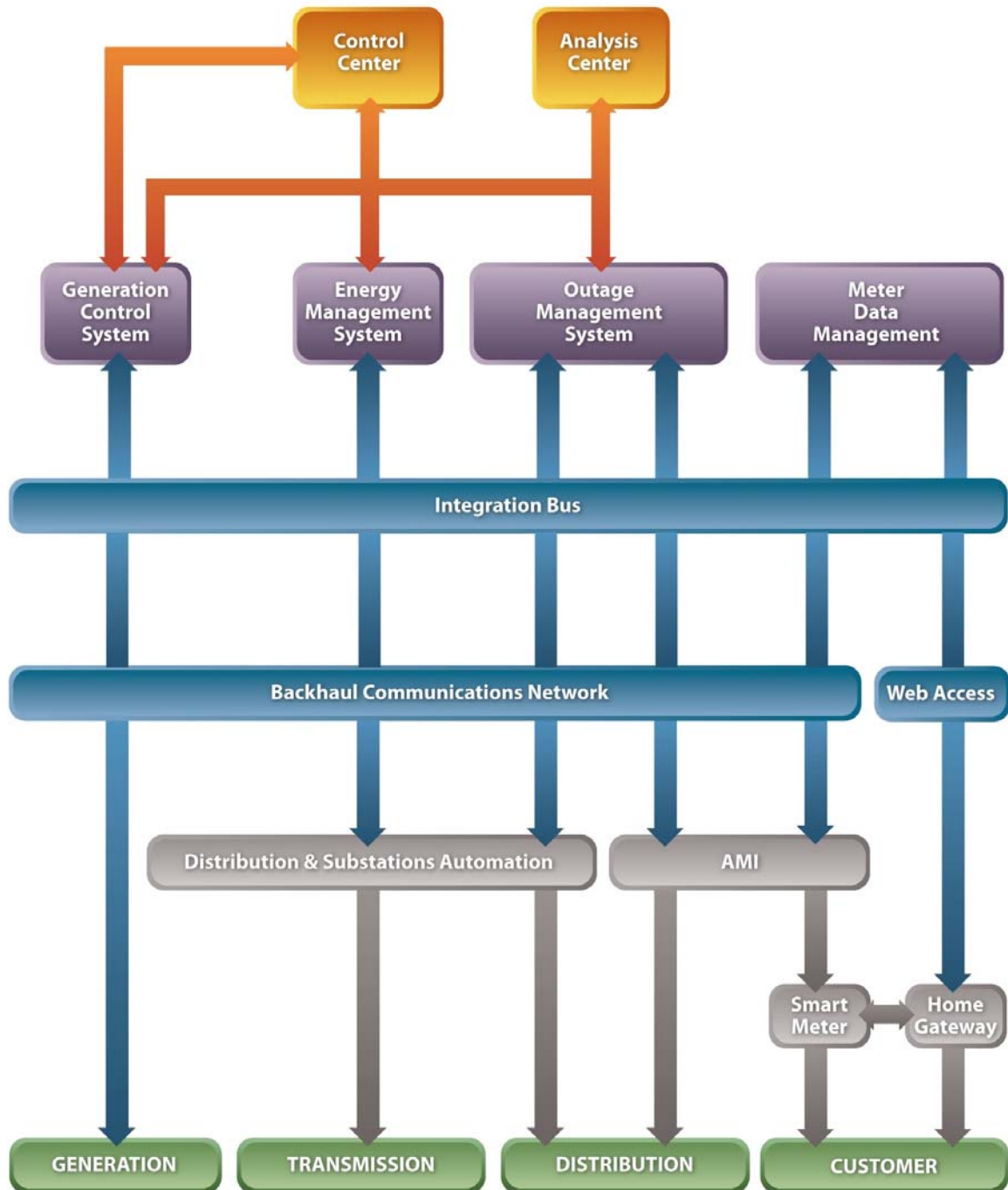

Figure 2.4. Top Level View of Interoperability: Smart Grid Systems

In figure 2.4, the transmission level upgrades required for the existing grid to transform into a smart grid are: Phasor Measurement Units (PMU), digital disturbance recorders, Intelligent Electronic Devices (IED) and microprocessor based protection. At

the distribution level, automated feeder switches, remote fault indicators, two-way protections systems with AMI are the select few items required. At the load side (customer), smart (AMI) meters with Home Area Network(HAN), renewable resources with DSM options are a few of the technologies needed in the implementation of a smart grid. The benefits of smart grid technology can be achieved if interoperability has been established in proper way. For example, AMI data will be used as follows to provide services in day-day operation:

- Since meters are on an AMI network, the response to any failure can be in micro or milliseconds. If power is lost due to failure, AMI meter can send a signal to the Outage Management System (OMS). After analysis, the OMS can decipher whether a repair service is required or if the fault will be cleared on its own (e.g. Failure of some load item like a refrigerator, TV etc.). To take care of such failure, there would not be any need for a call from the customer, and an automatic service routine will be triggered on receiving the signal from the AMI meter.
- Another scenario is when a customer calls because of an electricity outage in the house. The Distribution and outage management system will automatically know (from the AMI meter at customer premises) whether energy is available at the customer's doorsteps or not. Hence, many such failures can be resolved immediately rather than waiting for a service engineer to make a visit to the customer location. This will enable customers to easily acquire information regarding the nature of the malfunctions of their electricity.

- Similarly, if a repair has been recently completed, the AMI meter can verify automatically whether the service is restored or not.
- Furthermore, the AMI meter working in a network can confirm immediately whether power has failed in the region. This region can also be identified with help of Geographic information system (GIS) linked to AMI meters.
- Customer loading data will be improved dramatically through hourly usage data from AMI. Present day customer loads are determined by algorithms that have been present for many years. It is also determined by an estimated peak load for a customer based on the monthly reading. Load profiles are estimations based on customer type, season, and day. Using (estimated) diversity factors, data are aggregated to estimate transformer loading

## 2.4.10 Integration of Transmission/Substation Intelligence

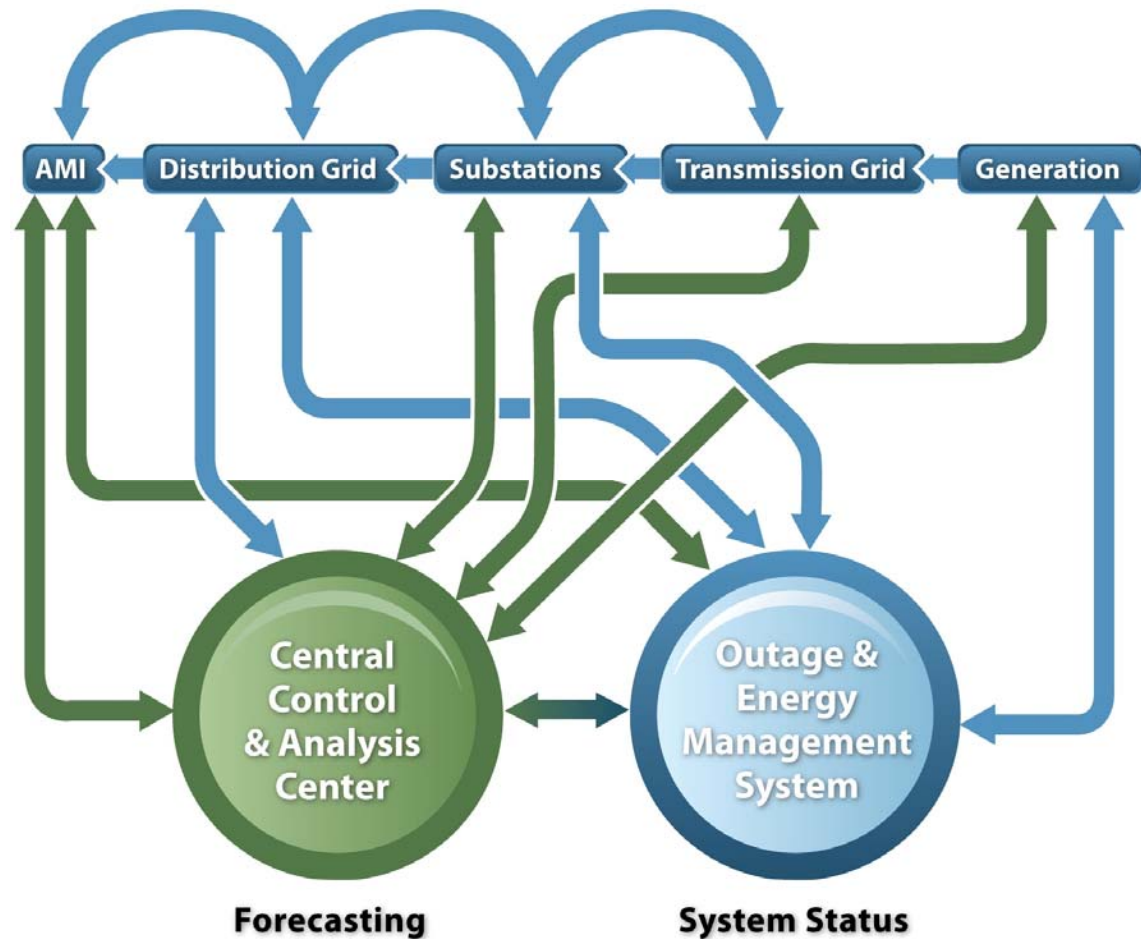

Figure 2.5. Smart Grid Coordination Across Generation, Transmission, and Distribution

Many power plants have already gained knowledge regarding the use of technology in monitoring critical equipment, while proactively performing preventative maintenance in order to extend asset life and improve reliability. This existing experience with central control tools, and proven success allow leverage for central control applications to improve Transmission and Distributions Grid's strengths [32 - 35]. In figure 2.5, the smart grid coordination picture is depicted. This concept would enable transmission and substation intelligence to operate in such a fashion that the auto load

management, feeder control, monitoring of equipment remotely and self healing concepts can be implemented.

This integration of multiple technologies to establish a smart grid poses new challenges as well [36-38]. There will be need of new tools to assess and predict reliability issues. The goal of this research is the development of new electrical system tools to monitor and analyze the relationship of weather and electrical infrastructure interruptions. The goal will be accomplished by modeling weather & distribution system reliability issues, developing forecasting tools and by developing mathematical models for the availability of the system with smart grid functionality. The expected results include the ability to predict and determine the number of interruptions in a defined region; a novel method for calculating smart grid system's availability; a novel method for normalizing reliability indices; and to determine manpower needs, inventory needs, and fast restoration strategies.

In the following chapter, we will address the modeling of weather and distribution system reliability, and the formation of a novel predictor will be displayed

## **CHAPTER 3: SMARTGRID RELIABILITY AND AVAILABILITY**

Electric grid infrastructure requires robust and intelligent systems that can respond dynamically to address natural or man-made faults and interruptions. The effects of weather (e.g. strong winds, rain, lightning, cold fronts, snow, etc.) on the electrical infrastructure are expected to increase in the near future. The resulting power interruptions produce economic hardships costing more than 80 billion dollars annually. Since the electrical infrastructure is fragile, every adverse weather system that passes over it presents a threat to the reliability of the power system. In case of a disruption due to weather, it is very difficult to supply energy and restore the system, especially if transmission and distribution lines are affected. These issues lead to innovation and to the next generation of power systems that must be flexible, reliable, and intelligent. Envisioned in these advances is a revolutionary way of sensing, intelligence gathering, and corrective actions. The goal of this endeavor is to provide near uninterruptible service during severe weather events, and the ability to monitor the critical electrical infrastructure in real time.

### **3.1 Introduction to Smart Grid Power Quality, Reliability and Availability**

The reliability of power distribution systems is dependent on many variables such as load capacity, customer base, maintenance, age, and type of equipment. Nonetheless, the variable most often cited for lowering the reliability of the system is weather.



Contrarily, the prevailing weather conditions are often overlooked in reliability analyses. These conditions include, but are not limited to: rain, wind, temperature, lightning density, humidity, barometric pressure, snow, and ice.

In order to analyze power system reliability with the aspects listed above, it is necessary to have stringent well-defined measurement and comparison methods. This practice is referred to as metrics [39]. The standards are being adopted; hence, it is wise to address the commonly used definitions for the metrics and indices.

### **3.1.1 Relationship of Power Quality, Reliability, and Availability**

Power quality is a general term; it has various definitions depending on the context in which it is used. For customers, if the load is negatively affected, there are power quality issues. For utilities, non-compliance of any parameters such as harmonics can be a power quality issue [39]. One of the definitions of power quality is: the absence of deviation from pure sinusoidal voltage. This definition makes all reliability issues (including customer interruptions) a part of power quality [39]. There are equal numbers of groups which identify power quality and power reliability issues as a subset of each other. The important point from the industry perspective is that the electric utilities gets penalized on reliability issues and thus their view is to have all aspects (including power quality) as part of reliability study. Customer interruption is if the voltage reaches zero (power not available for certain duration). This is a deviation from a pure sinusoid thus, a power quality issue. In general, it is agreed that power quality is a subset of power reliability; however, the demarcation of boundaries between the two is not so well-defined. Interruptions that exist for more than a few minutes are called sustained interruptions and are regarded as a reliability issue. Whereas, interruptions that exists for

less than few minutes are known as momentary interruptions, and are classified as power quality issues. The reasons are: [39]

- Momentary interruptions happen during intentional operating practices.
- Momentary interruptions do not generate large numbers of outages/ customer complaints.
- Difficult to measure

However, in the modern age, all kinds of interruptions, including momentary interruptions, count as important customer issues and thus, are considered a reliability issue.

The third classification is ‘Availability’. Availability is defined as the percentage of time a voltage source remains un-interrupted . Since availability is defined in terms of interruptions (un-interruptions), it is considered a subset of reliability. For our purposes, power quality, reliability, and availability are shown in figure 3.1 as a Venn diagram. Availability is a subset of power quality and power quality in turn is a subset of power reliability.

In summary, power quality deals with deviation from a pure sinusoidal voltage and/or current waveform. Reliability addresses all kinds of interruptions and availability deals with the probability of being in an interrupted state.

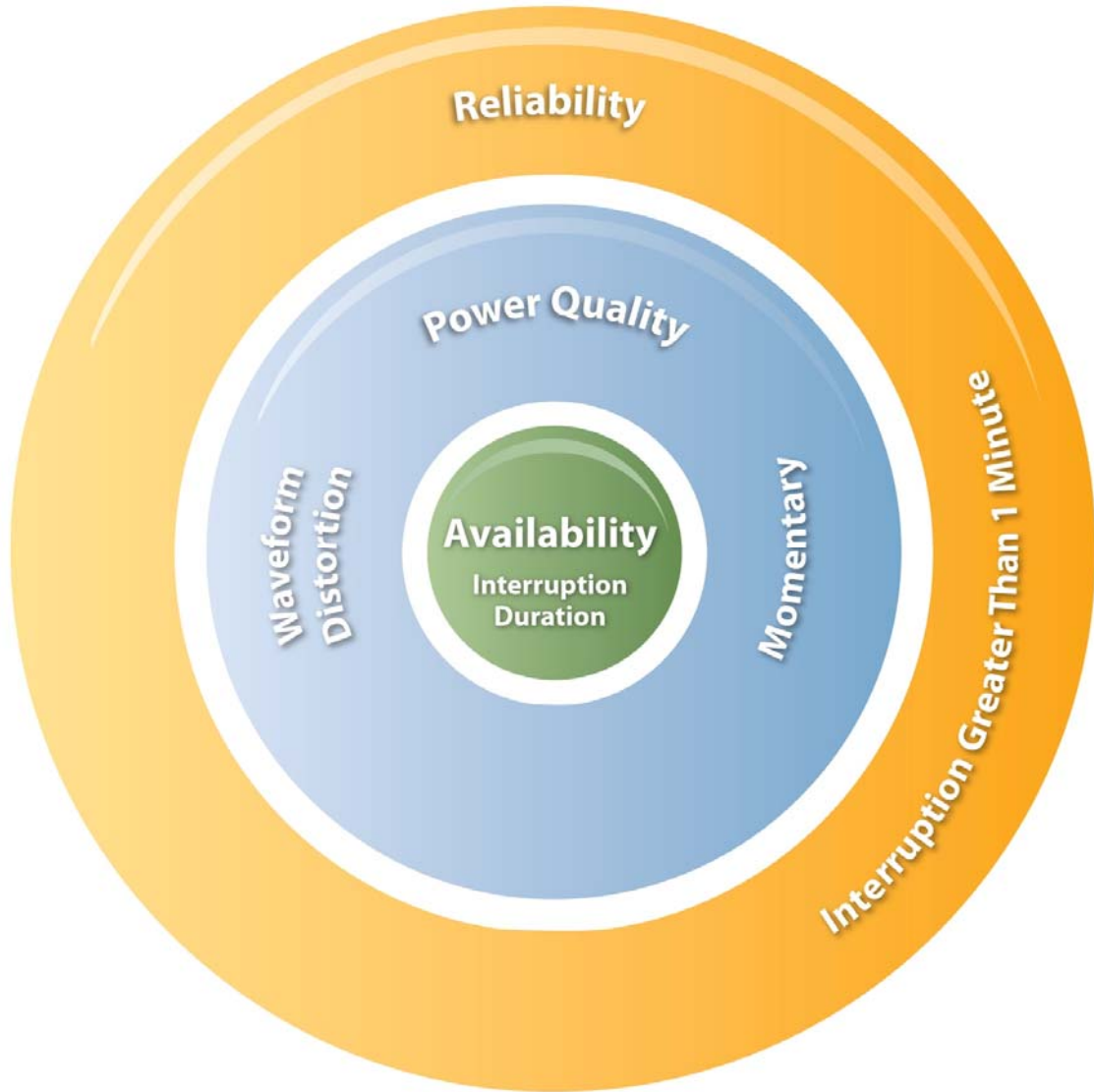

Figure 3.1. Availability, Power Quality and Reliability Shown as Subsets of Each Other

### 3.2 Power System Reliability, Availability Metrics, and Indices

In this section, important definitions and statistical/aggregation formulae's that are required to fully understand power system reliability and availability, will be explained.

#### 3.2.1 Reliability

Electric power distribution reliability primarily relates to equipment outages and customer interruptions. Under normal operating conditions, all equipment is energized

(except backup/standby) and the electricity is available to all connected customers.

Scheduled and unscheduled events create disruptions to normal operations causing outages and interruptions. Some of the key parameter's definitions are given below [39]:

- Contingency: An unexpected event, such as a fault or an open circuit; an unscheduled event.
- Open Circuit: A point in a circuit that interrupts load current without causing fault current to flow. False tripping of a circuit breaker is an example.
- Fault: May be defined as a short circuit. It is the breakdown of dielectric insulation of the system. If it clears on its own, it is termed as a self-clearing fault. If the fault is cleared by de-energizing and re-energizing the circuit, it is called as temporary fault. If the fault requires manual intervention for repair, it is termed as a permanent fault.
- Outage: When a piece of equipment is de-energized either by scheduled or unscheduled event, it is termed as an outage. Un-scheduled outages happen due to contingencies.
- Momentary Interruptions: When a customer is de-energized for less than a few minutes, it is termed a momentary interruption. Most of these happen due to closing of automated switches.
- Momentary Interruptions Event: If multiple momentary events happen during a short duration of time (several minutes), it is counted as one momentary event.
- Sustained Interruption: A sustained interruption occurs when customer is de-energized for more than few minutes. These situations arise from faults and open circuits.

Maximum duration of momentary interruption varies from utility to utility. Most

utilities follow the guidelines set up by the Public Service Commissions (PSC) in their individual service area states. Generally, it is considered less than 1 minute. IEEE 1366 standards [40] identify any interruptions for less than 5 minutes as momentary. This is done to make sure that an automated switch can take care of the fault (if possible), and that the interruption is listed as momentary. However, most of the automated equipment cannot take care of faults in less than a minute. Because of this, the reliability indices' calculations are more accurate and promote the use of automation in the industry.

### **3.2.2 Availability**

Availability is the probability of something to be energized. It is calculated in percentage or per unit. The complement of availability is un-availability. The annual interruption time can be estimated by comparing the percent availability between 90% and 99.9999999%. By comparing the number of 'nines' in the % availability, an estimate to the annual interruption time(AIT) can be given. For example, if the availability is 90% (1 nine), the AIT is 36.5 days. At 99% (2 nines), AIT drops to 3.7 days, while at 99.9%(3 nines) it drops even further to 8.8hrs. Following this trend (AIT dropping by a factor of 10 with every additional 'nine'), an availability of 99.9999999% have an AIT of 1.9 cycles (60HZ) or 31.67 ms. This being said, if a customer faces 9 hours of outages in a year, the un-availability is =  $9/8760$  hours which is 0.1%; the availability is  $100 - 0.1 = 99.9\%$ .

### **3.2.3 Reliability Indices**

Appendix A provides a list of definitions and formulae for calculations of various short-term and long-term reliability indices. The mathematical formulations of various

indices are provided with other parameters [40]. Further discussions regarding the calculations of various reliability indices are done in chapter 4 and 5.

### **3.3 Interruption Causes and Modeling**

As discussed earlier that the reliability of power distribution systems is dependent on many variables such as load capacity, customer base, maintenance, age and type of equipment. Ironically, the variable most responsible for decreasing reliability is weather, which is often overlooked in reliability analysis.

Reiterating that the weather and environmental conditions to be addressed includes, but are not limited to, rain, wind, temperature, lightning density, humidity, barometric pressure, snow, and ice. The models are developed to allow broad application, since these conditions do not occur simultaneously at any one place, and the range of combinations is great. Using the data collected, statistical and deterministic simulations of the models are done by employing existing software; the results will be used to refine the models. In order to validate the models, power interruptions will be predicted in areas that can be easily monitored. The following section explains each important cause of power interruption and their respective models are explained.

#### **3.3.1 Equipment Failure**

Distribution networks have various kinds of equipment installed to make sure that the electricity supplied is safe and secure. When first installed these equipment have a greater chance of failure due to manufacturing defects, incorrect installation, and damage due to shipping and handling. Equipment already in place (in circuit) for some time, may fail due to extreme electrical conditions such as continuous overload, high voltage, and variable weather conditions (including lightning). Furthermore, the equipment may also

fail due to changes in the chemical composition, aging, and mechanical wear [39]. We will try to address some of these issues and discuss certain models for equipment failures.

The rate of equipment failure needs to be modeled for electric utilities to plan, engineer, and operate a system at the highest levels of reliability for the lowest possible price [43]. Some utilities however, have a problem with the type of equipment being used [44]. Most utilities perform regular equipment inspections and have tacit knowledge that relates inspection data to the risk of equipment failure. One of the methods used to improve the accuracy of the system is by using equipment inspection data to assign relative condition rankings. These rankings are then mapped to a failure rate function based on worst-case units, average units, and best-case units [43].

### **3.3.1.1 Transformers**

The transformer is a key component for any distribution network. Reliability issues of transformers can happen in two related ways; overload and failure [39]. Transformer forms a sort of bottleneck in the earlier distribution network. If there is a major failure in the transformer then there can be power interruptions to thousands of customers. In order to handle such situations, other transformers are tasked with taking over the entire load or with sharing the interrupted load. If no spare transformer capacity is available, a decision is made to overload other in-service transformers, resulting in the deterioration of longevity for those transformers. This process compromises either improving the current reliability, or increasing the probability of future transformer failure. Understanding transformer ratings and thermal aging is critical in making the right decision during such a situation of reliability risk management.

Transformer ratings depend on the expected life of the winding insulation at a specified temperature. Standard transformer ratings are designed at a 30°C ambient temperature while average winding temperature rises from 55°C or 65°C with an additional hot spot rise of 10°C or 15°C. Often, the life of the transformer is defined as the time required until it deteriorates to 50% of its mechanical strength. This occurs due to a breakdown of insulation because of excess heat [39].

Temperature rise is a key factor for transformer failure. The temperature rise can be either due to the load or due to harsh weather conditions. Thus, it is of high interest to look at the impact of the rise in ambient temperature, and number of power interruptions due to transformer failure.

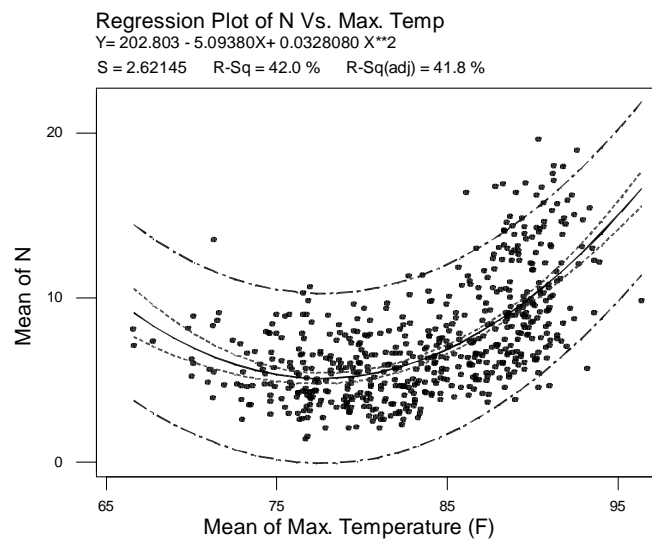

Figure 3.2. Variation of Average N due to Transformer Failures Versus Maximum Temperature [45]

The monthly averages (means) of the maximum temperatures and the monthly means of the total number of interruptions due to transformer failures, for 4 years (1998-2001) of data collected from the South Florida region is shown in figure 3.2. With these



conditions, the total number of monthly data points is approximately 567.

The legend for figure 3.2 is as follows:

——	Regression	PI – Prediction Interval limits
-----	95% CI	
- - - - -	95% PI	CI – Confidence Interval limits

In the figure 3.2, the two peaks on each side of the graph maybe due to the overloading of transformer at these temperatures. It appears that around 75<sup>0</sup>F to 80<sup>0</sup>F, the temperatures are in the comfort zone of the human body and thus the need of excess power is not there. There will not be an increase in transformer failure interruptions because it is an optimal operating temperature. After Approximately 80<sup>0</sup>F however, the curve increases in an exponential way (right-skewed). This indicates that the effects of higher temperatures not only cause more interruptions, but also are more predominant than those of lower temperatures are; these effects are expected in Florida, whose climate is tropical and sunny throughout the year. If we average the data points [45], a clear pattern is observed between the variables by suppressing the disturbances/noise in the data set. The important point that should be observed is that as the number of data points decreases, the plot becomes smoother with the increase of the R<sup>2</sup> value.

In the variables given in the equation after the regression analysis(next to the plots), R<sup>2</sup> represents the proportion of variability in the Y variable accounted for by the X variable. Given the maximum temperature of a day, it is therefore possible to predict the total number of interruptions from a transformer for any management area (MA).

### 3.3.1.2 Underground Cables

Underground cables provide better ruggedness and are more effective against many above ground reliability issues. The tradeoffs are long downtimes in case of

failures and high cost. Major issues with underground cables are electrochemical and water treeing. When the moisture penetrates in presence of an electric field, the dielectric strength of the cable insulation is reduced; this is called treeing [39]. Known as treeing, the moisture permeates the extruded dielectrics of the insulation such as cross-linked polythene (XLPE) or ethylene propylene rubber (EPR); the breakdown patterns resemble a tree [39]. This in turn reduces the voltage withstand capability of the cable. With time, the insulation strength degrades so much that the voltage transients, such as lightning or switching, causes dielectric breakdown. With an increase in temperature, the moisture absorption also increases; there is a strong correlation between thermal aging and treeing [39].

Water treeing in XLPE cables is a costly reliability issue for utilities.

Manufacturers of cables have developed jacketed and tree retardant cables (TR-XLPE). Cable jackets prevent moisture to seep in. The tree retardant reduces the development of a tree inside the cable after the moisture seeps in. Treeing is attributed to impurities and imperfections, which enter during the manufacturing process of cables. Quality control over manufacturing and testing of cables before installation largely improves reliability.

### **3.3.1.3 Overhead Lines**

Overhead lines reliability issues are mostly caused by external factors such as vegetation, animals, and variable weather, which will all be discussed in detail in the following sections. Bare conductors fair better in terms of temperatures and high current capacity. In any case, higher currents do affect reliability and can cause sagging, annealing, and breakdown if a fault current is not cleared fast enough [39]. Overhead lines are installed on poles. Earlier poles were of wood but recently, the new norm is to

replace wood poles with concrete poles whenever required. This improves physical ruggedness of the infrastructure under extreme weather conditions. The major reliability issue with poles is its capability to withstand high wind speed. The effects of wind on overhead infrastructure (e.g., poles, lines, pole mounted equipments) are also discussed in the following section.

#### **3.3.1.4 Circuit Breakers**

Circuit breakers have many components which increase the complexity of the equipment. With so many parts, the failure of circuit breakers can take place in many ways. Failure can be internally related to its own functioning. The two major reasons for circuit breakers failures are: (a) open when it should not, and (b) failed in service (cannot operate). These two failure modes constitute 74% of the reasons why failures in circuit breakers occur [39].

#### **3.3.2 Weather Conditions**

The reliability of electric power system has remained a challenge for years. The goal is to provide near uninterruptible service during variable weather events [46]. But due to the ever increasing demand and high expectations from customers, sometimes, power outages are simply unavoidable. Most power outages are caused by weather-related events [45]. Interruption may be defined as a loss of service to one or more customers. As stated before, interruptions may be caused due to many factors like equipment failures, animals, weather conditions (Common), severe weather conditions (extreme wind, tornados, hurricanes, swinging, galloping and Aeolian vibration, lightning storms, ice storms, heat storms, earthquakes ,fire, etc), trees, human factors, and other causes. Extreme weather is rare, but creates multiple faults on the grid that take a longer

lead time to restore power back to the customers. The next section talks about the effects of both extreme and common weather conditions.

According to figure 3.3, the distribution of identified causes of interruptions for the area being studied shows that weather contributes approximately 10% to the total number of breakdowns/faults (N). However, this document will demonstrate that as much as 50% of the variation from the mean(N) can be accounted for by weather, especially in distribution networks.

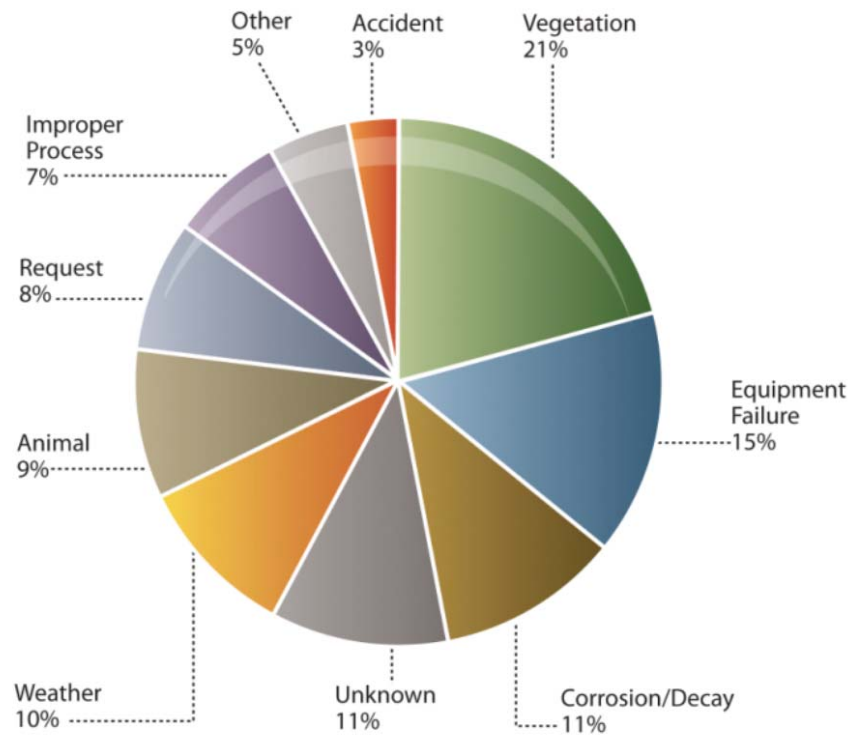

Figure 3 3. Distribution of Interruptions by Identifiable Causes

The regression models were developed using both raw weather data and weather data that was modeled to reflect their known effects on N.  $R^2$  was chosen as the statistic of interest because the  $R^2$  value of the regression result is the percentage of variance of the mean that is accounted for by the equation.

The following work also shows the analysis of, and modeling for, the power distribution system response to variable weather conditions. Included are the average temperature (T), two minute maximum sustained wind speed (S), daily total rainfall (R), and total daily number of lightning strikes (LS). The results show that the modeled equations return a consistently higher  $R^2$  value compared to equations that rely on raw weather data. Consequently, accounting for a larger percentage of the variance from the mean number of interruptions experienced daily.

### 3.3.2.1 Wind

As we see changes in the climate, many things are affected including the local weather, which has also shown extremities at many times. Wind plays havoc in the infrastructure if it reaches higher speeds. The study of wind flow is critical to power engineering. System designed wind flow studies are an important part of power engineering. They are used in system design, maintenance planning, and as an alternative source of energy. It is a known fact that the power of wind is directly proportional to the cube of the wind speed, it should not be surprising then that the electric power interruptions also show similar third order relationship to the wind speed.

Extreme winds can be linear or circular (tornadoes). There are four factors which attribute to the severity of windstorms; a function of sustained wind speed, gust speed, wind direction, and the length of the storm. Severity is dependent on the vegetation and climate as well [39]. A Hurricane is the name of a counter-clockwise rotating storm with wind speeds in excess of 74mph. Hurricanes cause damages to distribution system in many ways. Oftentimes it is caused by uprooting trees that fall and damage overhead distribution systems. Electric poles may also be blown away, or knocked down with high-

speed winds. Other effects of winds are swinging, galloping, and Aeolian vibration. Wind speed beyond a certain point has a huge impact on the number of interruptions. Figure 3.4 shows the relationship between wind speed and the mean number of interruptions in the region. The available data from the present weather recorder diminishes beyond 32MPH. [47].

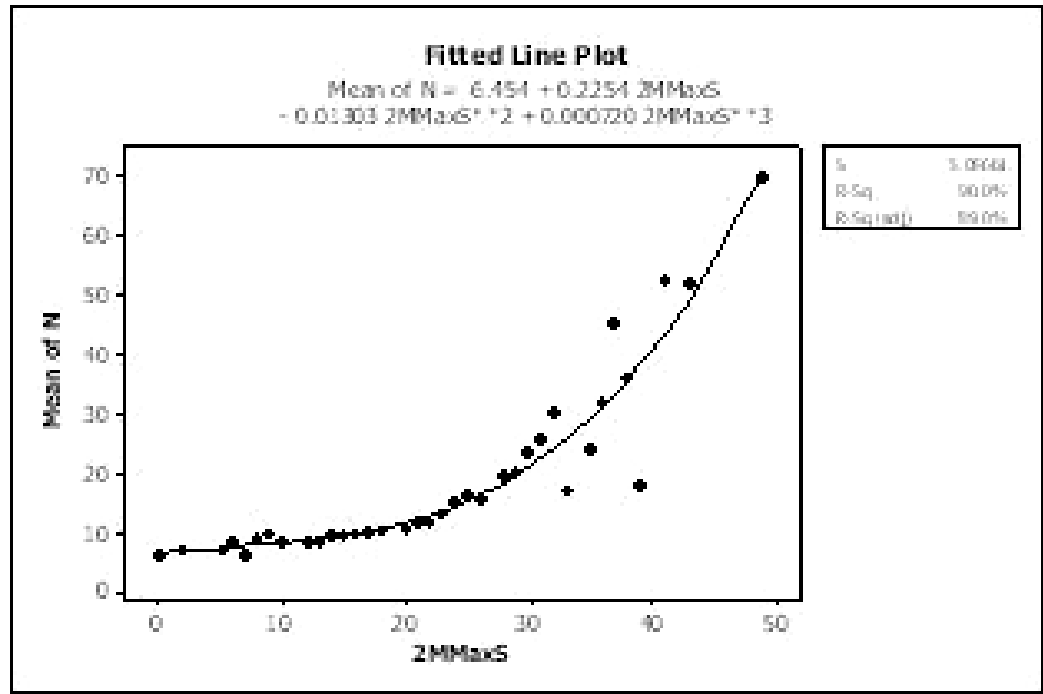

Figure 3.4. Variation of Mean of N Versus Wind in Dataset being Analyzed [47]

The cubic relationship between wind speed and the mean number of interruptions allows the modeling of the effect of wind on the total number of interruptions as:

$$N_{avg} = Y_3 + B_1S + B_2S^2 + B_3S^3 \quad (3.1)$$

where S is a two-minute maximum sustained gust.

There is a very good correlation between wind and the total number of interruptions (N) [47]. No significant pattern emerged when the plot was drawn between the daily 2 min. maximum wind gust (TMMG) speeds (mph) and N.

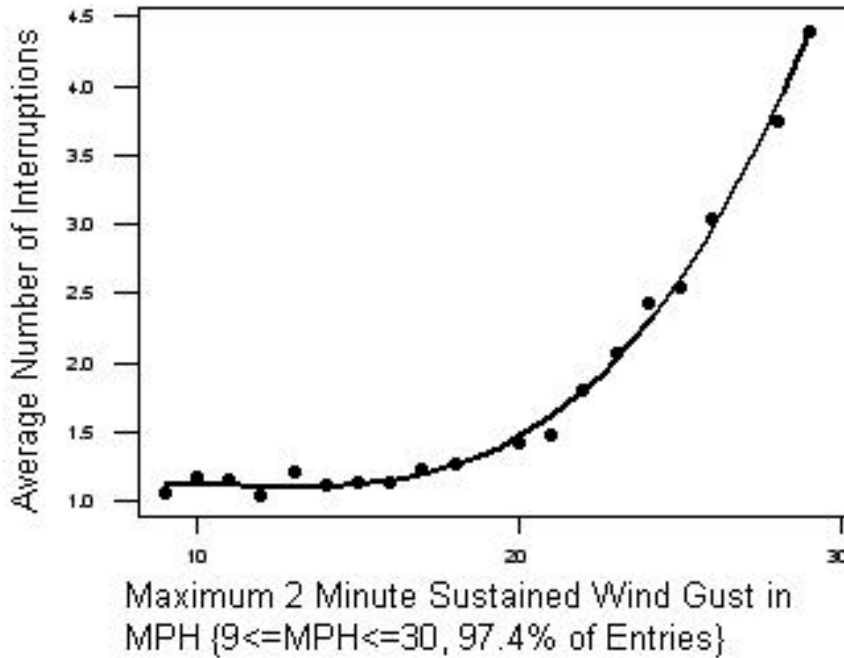

Figure 3.5. Variation of N Versus Wind

For a given value of the TMMG speed, there are different levels of N. Shown in figure 3.5, the plots of the averages of different levels of N occur at each of the speeds of TMMG.

From this graph, until wind speed reaches 40mph, there is a visible pattern, beyond that, no emerging pattern is visible. A pattern might have emerged if the TMMG speed levels (greater than 40mph) have happened at least 30 times during the 4 years of 1998-2001. Other lower speed levels accounted for for 98.5% of the total data set. Similar to figure 3.5, it can be observed from figure 3.6 that the correlation obtained through this process is very high,  $R^2 = 99.3\%$  and reveals the existence of strong cubic relationship between N and TMMG.

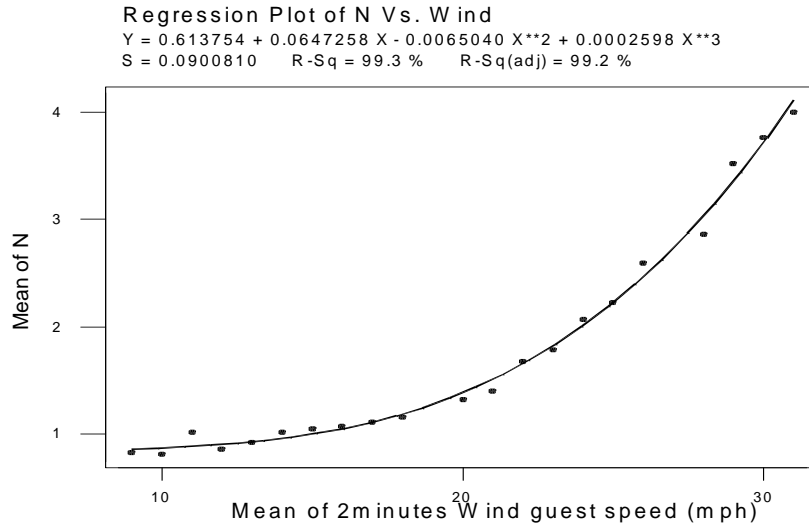

Figure 3.6. Mean of 2 minutes wind speed vs. average number of interruptions[47]

From figures 3.5 and 3.6 after 20mph it can be observed that the total average number of interruptions increases exponentially. Accordingly, power distribution poles and overhead equipment, are designed in such a way that there will not be any disruption arising from wind gusts in excess of 20 mph. At present the latest norm is to design system to withstand Category 3 hurricane (in the regions where wind speeds are high). Most of the infrastructure is old and can only withstand 90MPH winds gusts. Beyond this point the electric grid infrastructure faces extreme damages and restoration time runs into days and months.

### 3.3.2.2 Ice Storms

Ice storms occur when super cooled rain freezes on contact with conductors and tree branches, forming ice layers. This happens when the ground temperature is below freezing and a winter warm front passes through that area. Ice buildup increases the surface area facing the wind and hence loads excess weight on the conductor and the poles, causing them to either gallop or break. Additionally, tree branches with ice buildup



can break and affect the overhead distribution network. Ice loading can be computed as follows [39]:

- $W_i = 1.244 \times T \times (D + T)$  [3.2]
- $W_i$  = Ice load (lb/ft)
- $T$  = Radial thickness of ice (in)
- $D$  = Conductor diameter (in)

Typical assumption for ice density is 57-lb/ft [39]

Wind loading is calculated by wind pressure, multiplied by the conductor diameter, plus ice thickness:

- $W_w = \frac{V^2 \times (D + 2T)}{4800}$  (3.3)

- $W_w$  = Wind load (lb/ft)
- $V$  = wind speed (mi/hr)

The ice load and the wind load may or may not be in the same direction, regardless, the total conductor load is computed as a vector sum of the two values:

- $W = (W_c + W_i + W_w)$  (42)
- $W$  = Total conductor load (lb/ft)
- $W_c$  = Bare conductor weight (lb/ft)

Overhead distribution systems are designed to take care of expected icing and wind conditions.

### **3.3.2.3 Heat Storms**

Extended periods of exceedingly hot weather create their own issues for distribution networks; such situations are termed heat storms. High ambient temperature creates two types of issues: 1.) The equipment cannot dissipate as much heat to the surrounding air, 2.) The demand for electricity increases tremendously with the extensive use of air conditioning.

### **3.3.2.4 Rain**

The primary weather parameters contributing to N in the area under study are wind, temperature, rain, and lightning. In the earlier discussion in this chapter the correlation between wind, temperature and N has been shown. Studies that include other parameters such as humidity have shown considerably less correlation with N. If we plot four years of rain (RAIN) data with respect to the time in months, many general conclusions can be drawn. The plots are shown below (figures 3.7 – 3.10). The Rain data is in inches (in):

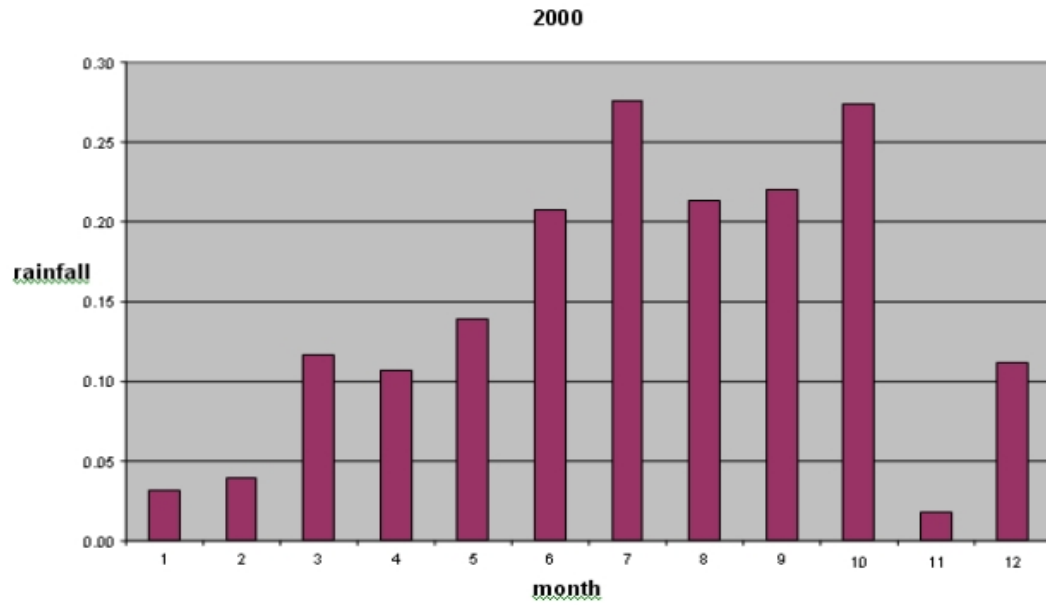

Figure 3.7. Monthly Mean Distribution of Rain for year 2000 [46]

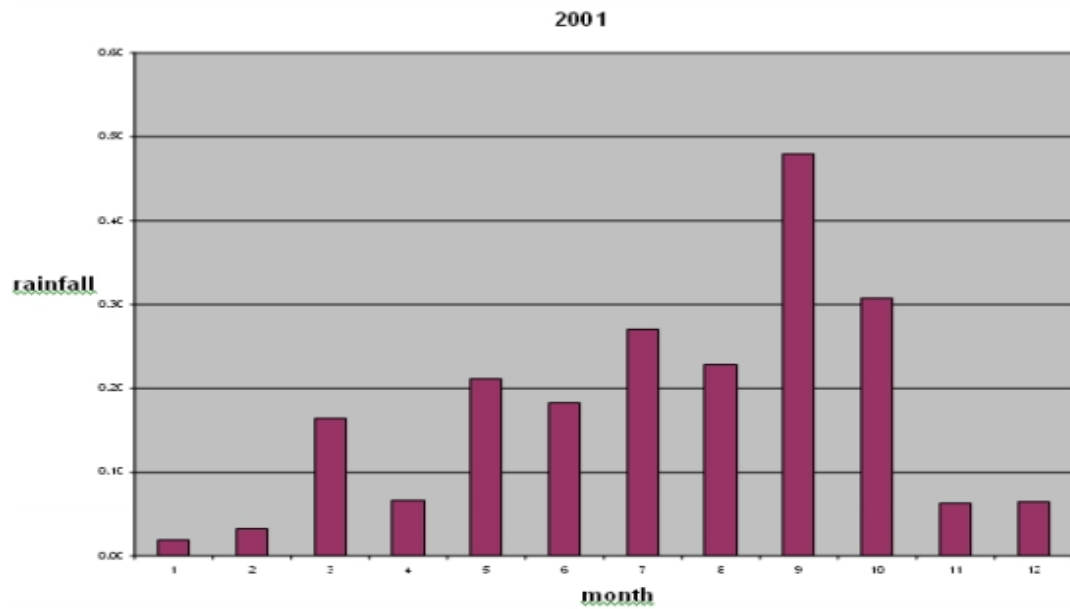

Figure 3.8. Monthly Mean Distribution of Rain for Year 2001 [46]

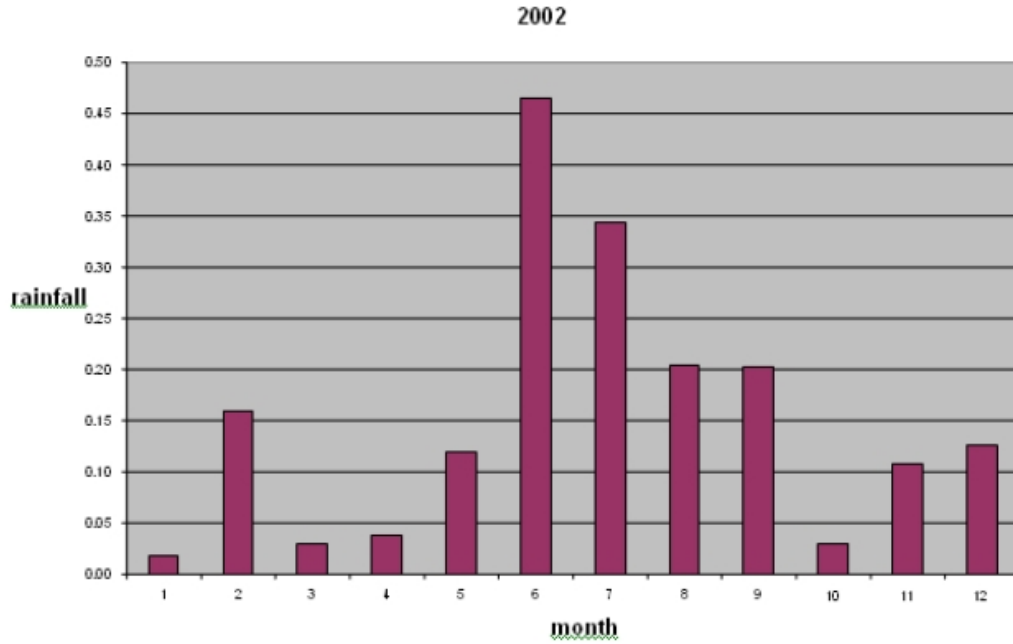

Figure 3.9. Monthly Mean Distribution of Rain for Year 2002 [46]

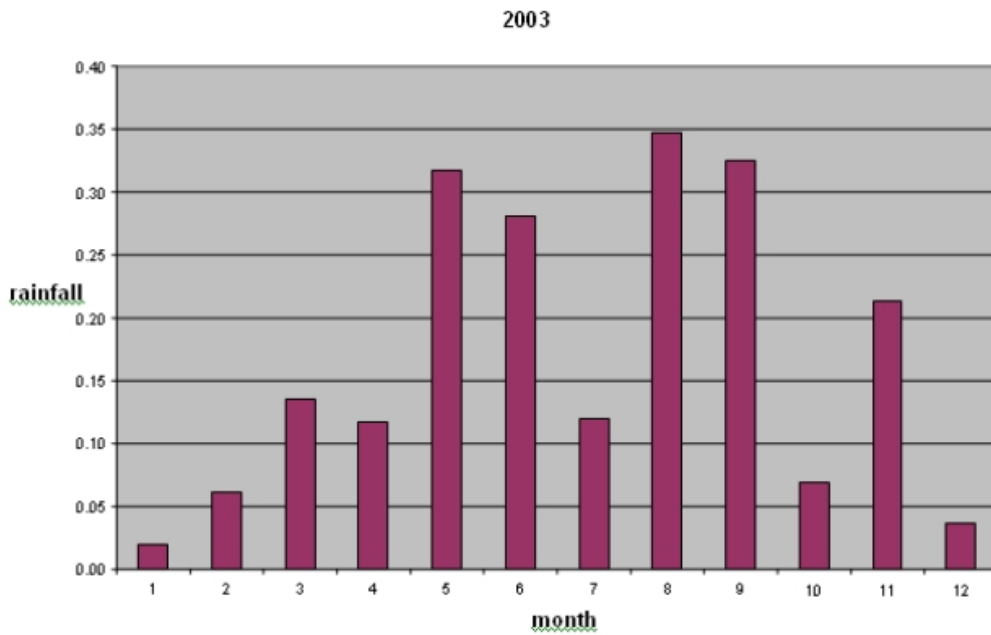

Figure 3.10. Monthly Mean Distribution of Rain for Year 2003 [46]

There is a piecewise relationship between the rain and the number of interruptions,  $N$  in a region. Rain does not only affect this relationship directly, but also

through vegetation and other effects like rusting and the insulation failures of equipment. Once the rain is in excess and the vegetation gets saturated; there is a good chance of a tree limb falling on the distribution network if proper tree trimming has not been done. Further the soil weakens with continuous rain and causes erosion which further escalates tree falling. Using all of these facts and modeling the rain as a piecewise linear function against the total number of interruptions in a region; the following equations are developed with three segments:

$$R1 = 0" \leq \text{Rain} < 1" \text{ and } 0 \text{ elsewhere} \quad (3.5)$$

$$R2 = 1" \leq \text{Rain} < 2" \text{ and } 0 \text{ elsewhere} \quad (3.6)$$

$$R3 = 2" \leq \text{Rain} \text{ and } 0 \text{ elsewhere} \quad (3.7)$$

In developing the model, the complete dataset was re-arranged to follow the above equation. The above definitions comprise the entire dataset, and the regression analyses were done using the following model equation for rain:

$$N_{avg} = Y_3 + C_1R1 + C_2R2 + C_3R3 \quad (3.8)$$

### 3.3.2.5 Lightning Strikes

A lightning strike occurs when the voltage generated between the cloud and the ground exceeds the dielectric strength of the air. Distribution systems are affected by lightning strikes in specific localized areas. Given below is the statistical analysis of lightning strikes (LS) in the region under study. Figures 3.15-18 show the monthly distribution of lightning strikes for the period between the years 2000-2003.

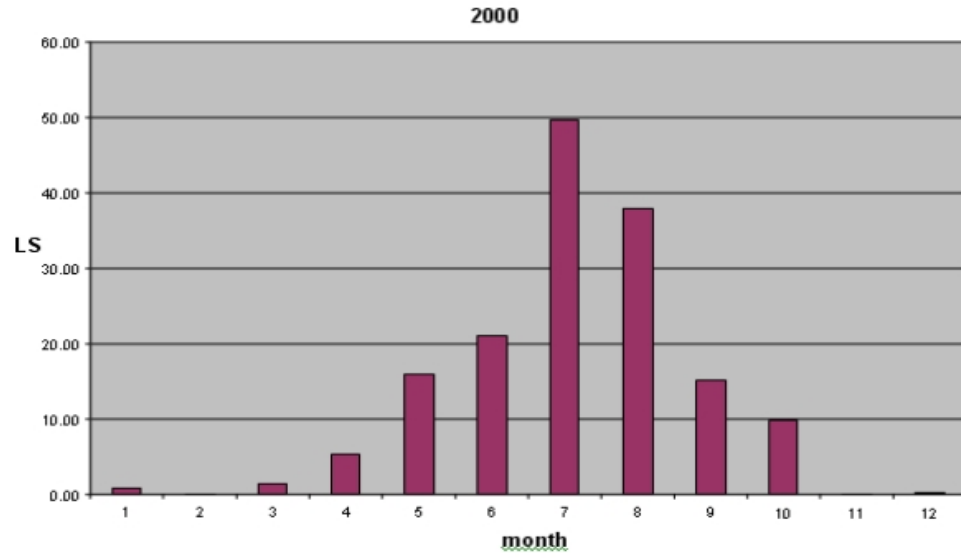

Figure 3.11. Monthly Distribution of LS for year 2000 [46]

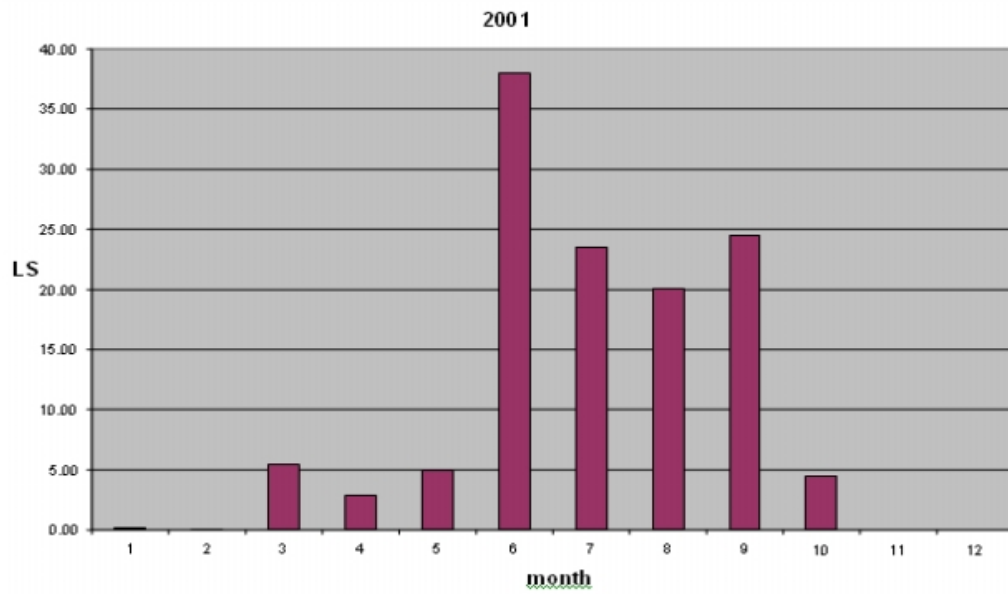

Figure 3.12. Monthly Distribution of LS for year 2001 [46]

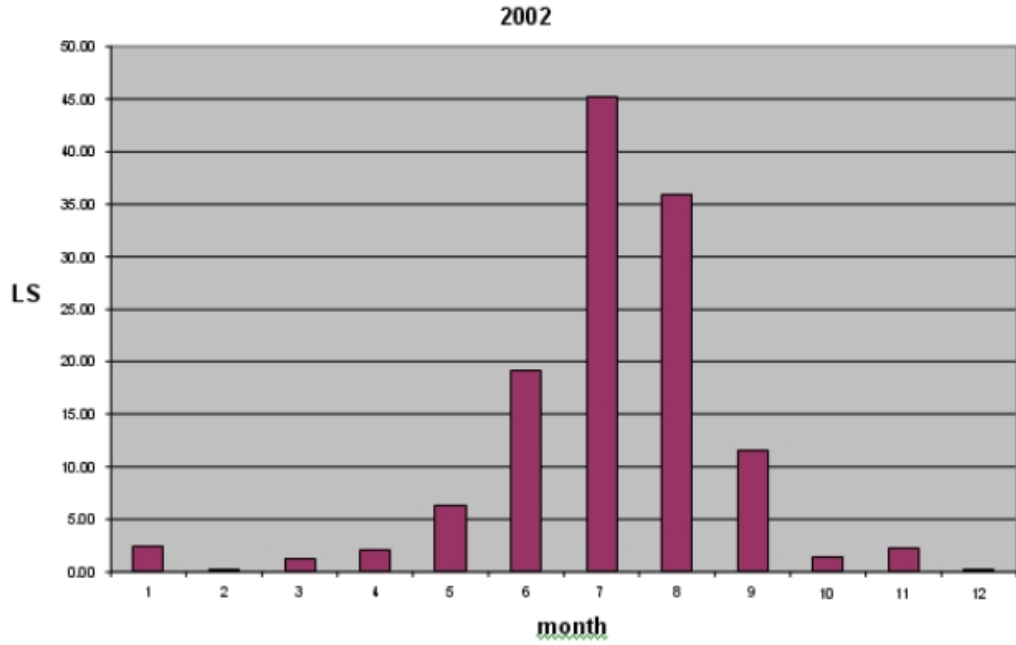

Figure 3.13. Monthly Distribution of LS for Year 2002 [46]

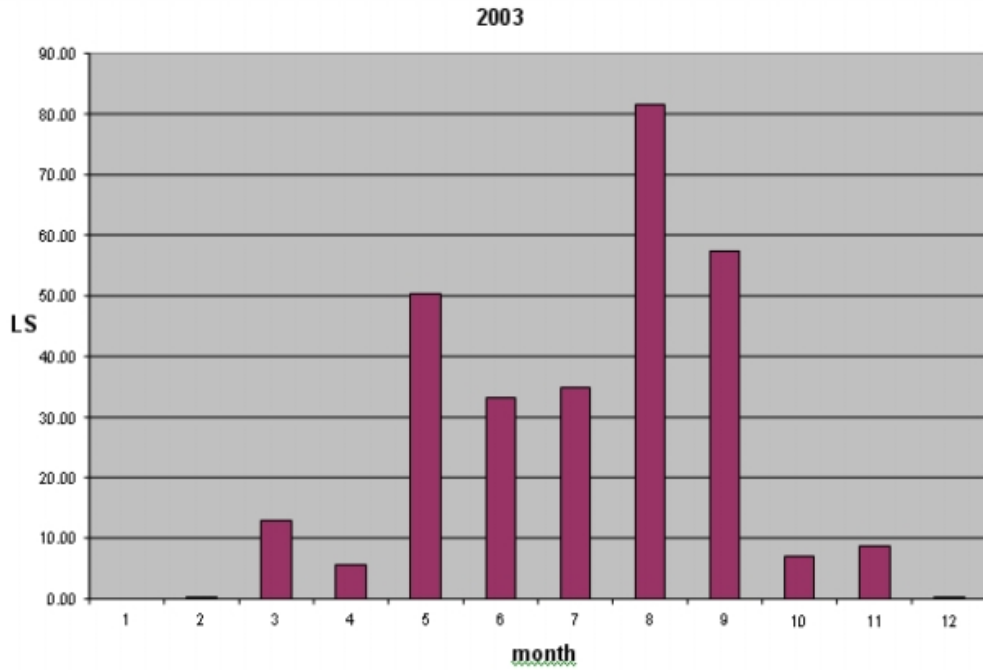

Figure 3.14. Monthly Distribution of LS for Year 2003 [46]

Based on figures 3.11-3.14, there is a year-to-year variation in monthly averages. The information would be misleading if the reliability reports were not adjusted for seasonal weather patterns. In addition, weather patterns change from year-to-year, and the number of interruptions either increase/decrease accordingly. Consequently, the preferred model needs to incorporate adjustments of the indices in both directions (making it a bilateral analysis). Further analysis over normalization of reliability indices is done in chapter 5.

In Florida, lightning tends to occur in storm cells that may be localized and only pass over a sparsely populated area [47]. Of course, it may also affect a heavily populated area where the majority of power lines are buried, thus LS can have a random, though important, effect on N. Generally accompanied with LS are the combined effects of strong winds and rain. Since there was sparse evidence for a narrow time-frame model of the effects of lightning, a linear predictor model was used instead. The model of lightning is given by:

$$N_{avg} = Y_4 + D_1LS \quad (3.9)$$

where LS is the daily total number of lightning strikes.

### **3.3.2.6 Temperature**

Previously discussed in section 3.3.1.1-Transformers, are the effects of temperature. This section will model the effects of temperature. The increase of N at low and at high temperatures can be attributed to the increase in power demand due to the heating/cooling requirements of customers [47].



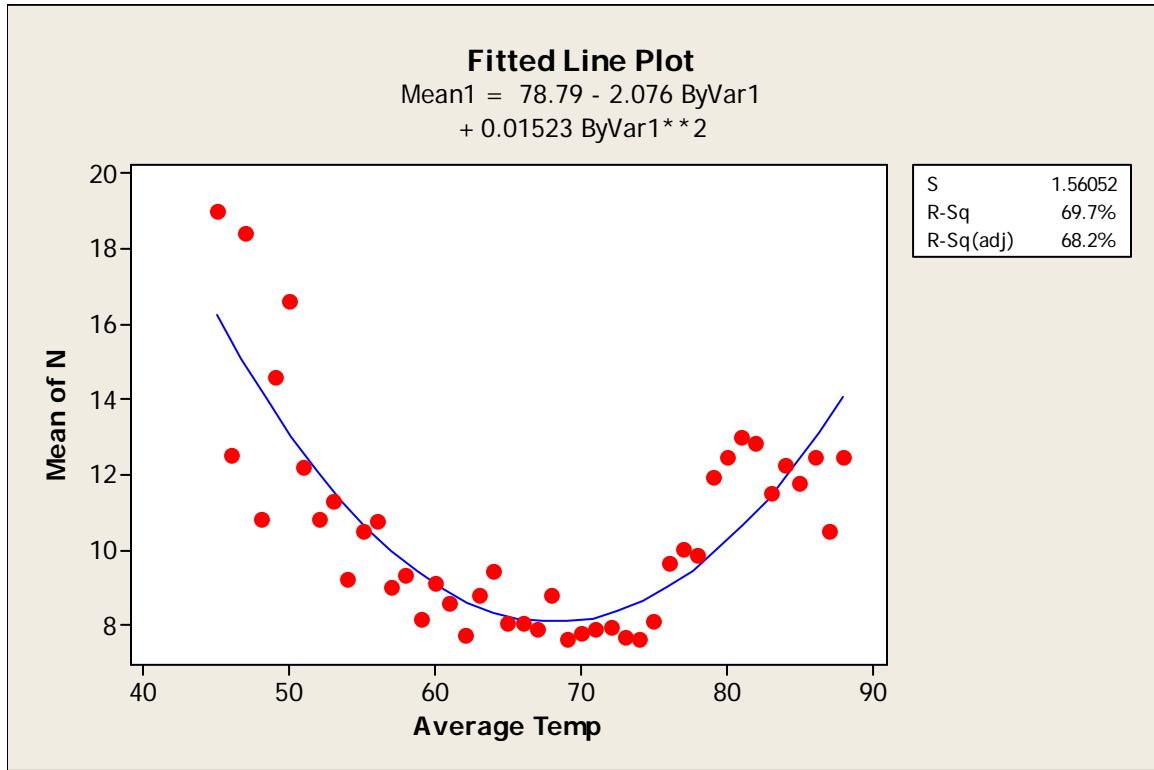

Figure 3.15. Variation of Mean N Versus Average Temperature [47]

Expressed as a regression equation, the relationship in figure 3.15 is:

$$N_{avg} = 78.79 - 2.076T + 0.01523T^2 \quad (3.10)$$

where  $N_{avg}$  is the mean number of interruptions and  $T$  is the average temperature.

Taking the derivative of (3.10) and equating it to zero, we see that at  $T=68.15^\circ\text{F}$ , which is where the minimum number of interruptions occur. Using integer values,  $68^\circ$  is considered the optimal temperature (OT).

Since the demand for power varies with temperature, the effect of ambient temperature movement away from the optimum temperature ( $OT=68$ ) was modeled. In the model, two parameters are defined, heating degrees (HD) and cooling degrees (CD). These parameters are available in the ASOS data; however, they are fixed with an OT of  $65^\circ$ , so it is desirable to recalculate using the local conditions. HD is defined as the

number of degrees below the OT existing on a particular day, while CD is defined as the number of degrees above the OT. Since the relationship between the average temperature and N is quadratic, this model will have second order terms for HD and CD.

The model equation for average temperature follows:

$$N = Y_1 + A_1HD + A_2HD^2 + A_3CD + A_4CD^2 \quad (3.11)$$

where  $A_1$ ,  $A_2$ ,  $A_3$  and  $A_4$  are the coefficients and are not equal to zero.

### 3.4 Optimization of Component Modeling

Earlier research work focused on modeling the effects of extreme weather conditions on power distribution systems, and on specific weather parameters causing specific faults in the distribution system. A theoretical model based on variable weather conditions is used to predict power distribution interruptions, while immediate weather conditions are used to analyze interruption risk assessment. Analyzing daily and hourly weather data, these models can normalize the reliability indices for weather and predict the number of daily or by shift interruptions.

Aside from the obvious culprits for interruptions (i.e. lightning, ground or line-to-line faults caused by vegetation and/or wind), the effects of common weather conditions on power reliability events have rarely been addressed. When exposed to natural wetting, such as humidity or rain, tests performed on contaminated insulators have shown that the electrical characteristics of the insulators are altered [41]. Lower barometric pressure causes coronal effects to be more pronounced which in turn can affect flashover rates [42]. In addition, other environmental phenomenon may also contribute to power reliability events in ways that are not considered.

Common weather excludes catastrophic events such as hurricanes or tornados, “which exceed reasonable design or operational limits of the electric power system” [1]. For extreme weather, there are methods being studied and ones already in place to define major reliability events, such as the aforementioned, while excluding the consequent interruptions from the calculation of reliability indices [2,3,4]. Since extreme weather physically damages entire power distribution systems, it also receives the most publicity which in turn takes up much of the focus on modeling the effects of weather [5,6,7]. There is also a body of work that includes weather as a factor in the analysis of specific fault causes [8,9,10]. However, there are no available models that consider the effects of common weather conditions, in order to predict the total number of daily or by-shift interruptions.

Reiterating that the weather and environmental conditions to be addressed include, but are not limited to, rain, wind, temperature, lightning density, humidity, barometric pressure, snow, and ice. The models are developed to allow broad application, since these conditions do not occur simultaneously at any one place, and the range of combinations is great. Using the data collected, statistical and deterministic simulations of the models are done by employing existing software; the results will be used to refine the models. In order to validate the models, power interruptions will be predicted in areas that can be easily monitored.

### **3.4.1 Area Under Study**

One of the largest utilities in Florida has been providing reliability and lightning data to support this research. In addition, weather data from the National Climatic Data Center (NCDC) is available to academic institutions or governmental bodies. This data is

reported by 886 automated surface observation stations (ASOSs) located at airports around the country [49]. As many as 15 Management Areas (MA), each providing thousands (for daily) or tens of thousands (for hourly) of lines of data, can be combined with weather data to create the files used for statistical or neural network analysis. This is a unique study of power distribution networks, never before done on this scale.

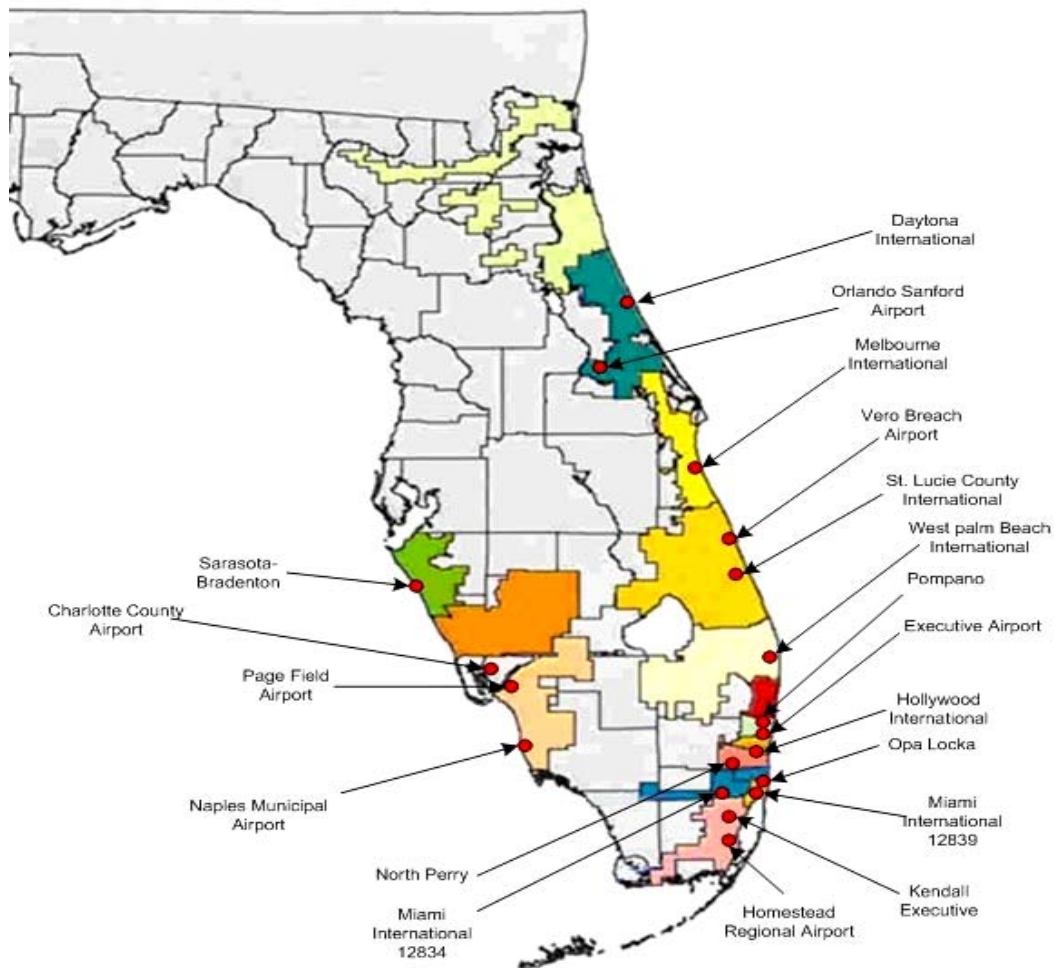

Figure 3.16. Location of Weather Data Recorder

In figure 3.16 the critical automated surface observation stations (ASOSs) are identified. As can be seen, some of the county regions area is quite far away from where the observatories are and hence the data does not depict exact weather conditions for

remote locations from the airport. To reduce such error, the utility companies are installing their own automated weather recorders.

The parameters being used to develop the combined predictor and risk analysis model is listed in table 3.1. The list contains weather parameters such as wind, rain, temperature and dew deposition. The lightning parameter and the outages or interruption parameter's data is provided by the utility providing services to the region of study. The data provided for research is listed in terms of the utility system. All these data are then processed in order to bring to a common scale and timeline.

Table 3.1. Weather, Lightning and Interruption (N) Codes and their Explanations Used for Combined Predictor Model

Call Sign	Call sign for the reporting airport
Date	Date
MaxTemp	Maximum temperature for that day
MinTemp	Minimum temperature for that day
AvgTemp	Average temperature for the day
DepNorm	Departure from normal
AvgDew	Average dew point
AvgWet	Average rainfall for that day
HeatDays	Days cooler than some specified temperature when customers are likely to use heaters
CoolDays	Days warmer than some specified temperature when customers are likely to use AC's
SigWeath	Weather station identifiers
Rain	Amount of rain in inches for that day
AvgStPR	Average atmospheric pressure for that day
AvgSeaPR	Average sea pressure for that day
ResWdS	Average resultant wind speed for that day
ResWdD	Average resultant wind direction for that day
AvgWdS	Average wind speed for that day
5SMaxS	Maximum sustained wind speed for 5 seconds for that day
5SMaxD	The direction of the maximum sustained wind speed for 5 seconds for that day
2MMaxS	Maximum sustained wind speed for 2 minutes for that day

Table 3.2. (Continued)

2MMaxD	The direction of the maximum sustained wind speed for 2 minutes for that day
Lightning Strikes	Total number of lightning strikes that day
Without Exclusions	Total number of outages for that day
With Exclusions	Total number of outages minus the total number of outages caused by allowable exceptions for that day
Weather.With Exclusions	Total number of weather outages for that day
Weather.Exclusions Only	Total number of directly correlated weather related outages minus the number of directly correlated weather related outages caused by allowable exceptions for that day
Outages.(Blank)	Total outages caused by unknown reasons for that day
Outages.Accident	Total number of outages caused by accidents for that day
Outages.Animal	Total number of outages caused by animals for that day
Outages.Corrosion/Decay	Total outages caused by corrosion and decay for that day
Outages.Dummy CFR	Total number of dummy tickets for that day
Outages.Equipment Failure	Total number of outages caused by equipment failures for that day
Outages.Improper Process	Total number of outages caused by improper process for that day
Outages.Other	Total number of outages caused by other reasons for that day
Outages.Request	Outages caused by customer request
Outages.Transmission	Total number of transmission outages for that day
Outages.Unknown	Total number of outages caused by unknown reasons for that day
Outages.Vegetation	Total number of outages caused by vegetation for that day
Outages.Weather	Total number of outages caused by weather for that day

### 3.4.2 Data Analysis and Processing

This study did not only develop novel combined theoretical models regarding the effects of common weather (while incorporating existing, relevant ones), but also applied them by solving the problem of predicting the daily number of interruptions. Real-time interruption risk assessment capabilities was also developed. As mentioned earlier, the data comes from the National Data Center (NCDC), and from one of the largest utilities in the United States. The weather data can be downloaded online and includes both daily

summaries and hourly, or even half-hourly, reporting. Additionally, the utilities are installing their own weather stations at service centers that are centrally located in their various management areas, providing an additional source of weather data.

The interruption data used to generate the models includes all interruptions described by all cause codes for an entire day. On the other hand, the weather data was relatively inaccurate because daily maximums and averages collected from point sources were not usually central to the area being studied. In order to model the data more precisely, the period in which the weather data is collected needs to be decreased from daily to hourly, and by improving the location of the point weather source.

Expanding to include weather variables not generally occurring in Florida, a better model can be generated. Using statistical methods and neural network theory while translating NCDC and SG interruption data into the proper format, models will be simulated and modified as needed. It has been shown previously that there is significant correlation between wind, temperature, rain, and N .

Using both raw weather data and pre-existing models, regression models were developed to reflect their effects on N. The regressions showed that by comparing  $R^2$  values, the effects of weather parameters are related and have a severe effect on N, if more than one of these parameters are at their extreme limit. These modeled equations improve the variability by up to 20% from the mean of N, compared to when raw data is used to form the mathematical models.

Given below in figure 3.17 are the excerpts of the data of various variables being used in developing the combined model of the predictor. Multiple sets of data are saved for comparison and analysis. Such as when comparing the variability between N and raw

weather data with the variability of N with modeled data. Further analyses were done to compare the variability after simulating using neural network software.

Call Sign	Date	Year	Month	MaxTemp	MinTemp	AvgTemp	DepNorm	AvgDew
CE	6/1/2008	2008	2	80	62	71	0	64
CE	6/2/2008	2008	2	79	58	69	0	59
CE	6/3/2008	2008	2	67	54	61	0	55
CE	6/4/2008	2008	2	70	57	64	0	60
CE	6/5/2008	2008	2	66	43	55	-6	49
CE	6/6/2008	2008	2	69	37	53	-8	46
CE	6/7/2008	2008	2	69	37	53	-8	46

AvgWet	HeatDays	CoolDays	SigWeath	Rain	AvgStPR	AvgSeaPR	ResWdS
66	0	0	FG+ FG HZ	0	30.05	30.11	1.5
62	0	0	FG HZ	0	30.04	30.12	5.7
57	0	0	FG	0	30.11	30.18	10.3
61	0	0	RA FG	0.12	30.03	30.12	4.7
52	10	0	RA FG	0.02	30.06	30.13	4.5
50	12	0	FG+ FG	0	30.11	30.18	1.9
50	12	0	FG+ FG	0	30.11	30.18	1.9

ResWdD	AvgWdS	5SMaxS	5SMaxD	2MMaxS	2MMaxD	Lightning Strikes	Without Exclusions	With Exclusions
6	7.8	16	5	15	5	0	5	5
36	10.9	31	1	26	1	0	8	8
1	11	22	2	17	2	0	5	5
35	6.8	17	1	14	35	0	12	12
33	6.7	20	33	16	32	0	7	7
5	4.8	14	9	13	7	0	14	14
5	4.8	14	9	13	7	0	14	14

Figure 3.17. Sample List of Key Data(raw) for Modeling a Combined Predictor

The development of the theoretical models began with the preexisting models and then expanded to include other variables to form a combined model. We have used



statistical and neural network software to simulate the models and modify them as needed. This additional data from other regions has broadened the range of weather conditions for which the models may then be validated.

The daily summary data used in this study has been able to create files with 40 columns and 14000 rows for computer analysis. The amount of data that requires archiving and correlating has increased tremendously, with the inclusion of hourly reporting and the use of interruption data from additional sources. The creation of a database that can manage that amount of information was the first priority. Additionally, the weather data that is downloaded from the NCDC is in ASCII format that is not readily importable to the analysis software. To advance the project, additional software was configured to handle the NCDC data, the weather data provided by the utility weather stations and any other data that is required that is not properly formatted. This document is not proposing to reinvent the wheel; the intent is to incorporate existing models to aid the ones being developed. For example, load prediction utilizing the temperature, humidity to find a human comfort zone (heating/AC), is a proven technology. Another example is that the probability of flashover due to ice buildup has been studied extensively [42] and may also be of use.

In order to validate these models, significantly accurate predictions of the number or frequency of interruptions must be produced. These predictions will be through simulations using actual weather and interruption data and will be probabilistic rather than deterministic, providing a means of risk assessment rather than a fixed value for the number of interruptions that can be expected. This provides a real capability to determine

risk. The  $R^2$  value of the predictions will be a statistic of interest for daily and by shift predictions, while narrower periods would include hourly risk probability assessments.

### 3.4.3 Combined Effects of Modeled Parameters

The equations of the models defined in sections 3.3.3, 3.3.5, 3.3.6, and 3.3.8 were combined to give a composite model of the effect of weather on N. The results from the aforementioned equations along with the combined equation, were compared with that which does not model the weather parameters. The combined equation for the raw weather data is as follows:

$$N = Y_5 + A \times T + B \times R + C \times S + D \times LS \quad (3.12)$$

The combined equation for the modeled data is as follows:

$$\begin{aligned} N = & Y_6 + A_1HD + A_2HD^2 + A_3CD + A_4CD^2 \\ & + B_1S + B_2S^2 + B_3S^3 + C_1R1 + C_2R2 \quad (3.13) \\ & + C_3R3 + D_1LS \end{aligned}$$

Regression analyses were performed on each of the five MAs individually using (3.1),(3.8),(3.9),(3.11),(3.12) and (3.13). Chosen as the statistic of interest, the  $R^2$  value of the regression equation, called the multiple coefficient of determination, describes the proportion of the total variation accounted for by the predictor variables [52]. Because our datasets had three years of daily data, the result of the additional seven new variables (degrees of freedom) caused us to negate the adjusted  $R^2$  (penalizing a model for having too many degrees of freedom).

The regression analysis done on the weather and N data with the raw data, (3.12), showed  $R^2$  values ranging from 36.9% to 43.3% for different MA's. The regression analysis on weather and N data with the modeled equation, (3.13), showed values ranging between 45.2% and 50.1% for different MA's. Similar results occurred when applying

the regression to individual weather parameters. The results are shown below in figures 3.18 and 3.19.

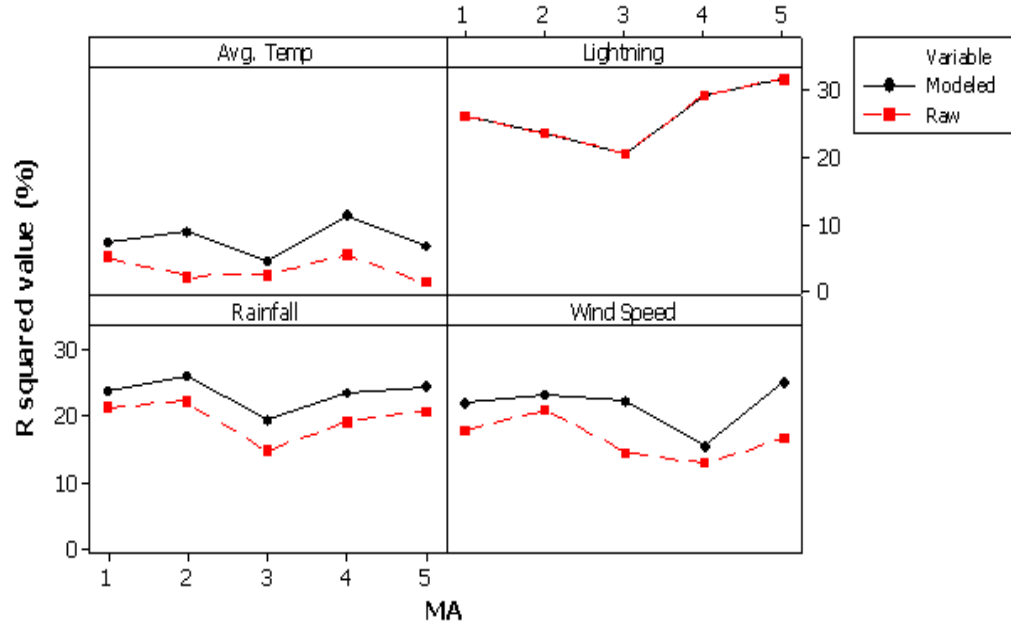

Figure 3.18. R<sup>2</sup> Values of Modeled Versus Raw Weather Data by MA and by Weather Parameter [47]

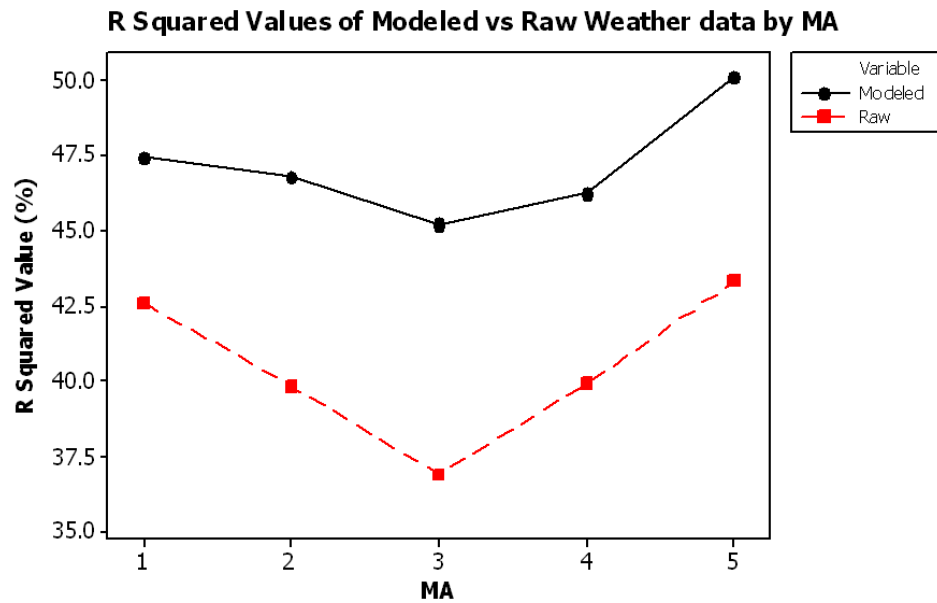

Figure 3.19. R<sup>2</sup> Values of Modeled Versus Raw Weather Data by MA [47]

To determine whether the association between the response and the predictor(s) in the modeled equation are statistically significant, it is necessary to set an  $\alpha$  level and compare the p-value for each predictor against the  $\alpha$  level. The usually accepted  $\alpha$  level is 0.050, and if the p-value is larger than this, the predictor is considered statistically insignificant. Table 3.2 below lists the p-values for each predictor by MA.

Table 3.3. P-values by Predictor and by MA [47]

	1	2	3	4	5
Constant	0.000	0.010	0.183	0.000	0.000
HD	0.719	0.000	0.795	0.003	0.003
HD2	0.633	0.000	0.141	0.013	0.039
CD	0.545	0.230	0.869	0.153	0.910
CD2	0.003	0.105	0.035	0.210	0.003
R1	0.001	0.000	0.000	0.000	0.000
R2	0.000	0.000	0.000	0.000	0.000
R3	0.000	0.000	0.000	0.140	0.000
S	0.000	0.083	0.459	0.000	0.004
S2	0.000	0.057	0.079	0.000	0.008
S3	0.003	0.210	0.000	0.002	0.075
LS	0.000	0.000	0.000	0.000	0.000

Figures 3.21 and 3.22 show that the modeled equations return a consistently higher  $R^2$  value than equations that rely only on raw weather data. This consequently accounts for a larger percentage of the variance from the mean number of interruptions experienced on a daily basis. It is not surprising to note that although lightning seems to have a dominant role in Florida, there is no single weather parameter that can be labeled as the primary cause. It is apparent that there are some combinatorial effects, since the  $R^2$  value of the combined equation is not the sum of the  $R^2$  values of its components. For example, lightning rarely occurs unaccompanied by wind and rain, but high winds and rain do occur quite often without lightning, so the role of lightning may be overstated by

the fact that it has the largest  $R^2$  value (figure 3.18) of all the weather parameters. Also, it appears from the  $R^2$  values for average temperatures, that it does not play a significant role in N. Figure 3.20 below shows a histogram of the temperatures that occurred over the study period. The area under study had a relatively narrow range of commonly occurring temperatures, with 95% of the average temperatures recorded ranging from 60 to 86 degrees, a 27-degree spread, which may not be true for regions outside of Florida.

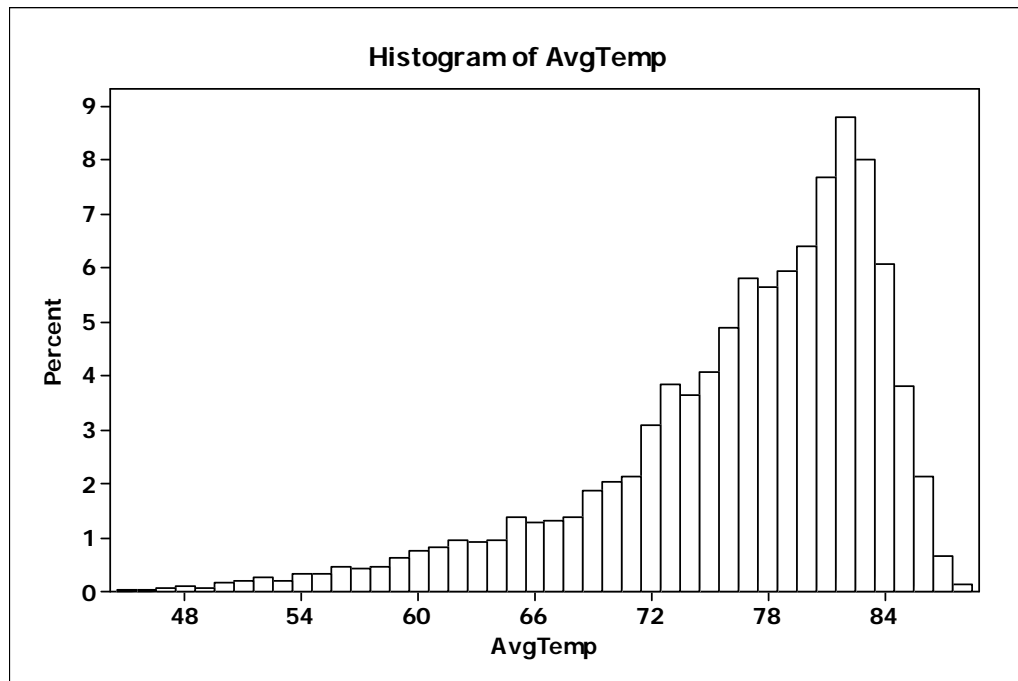

Figure 3.20. Percentage of Occurrences of Average Temperature for Combined Datasets

[47]

Some explanations for large p-values are uncommon occurrences of that variable in the dataset, or very small coefficients. In addition, when variables have large p-values, their contribution to the  $R^2$  value is marginal. Although HD and HD<sup>2</sup> rates model predictors as rejections 4/10 times in Table 3.2., figure 3.20 shows that there may not have been enough days below the OT to consider them significant. CD, on the other hand, does not seem to be significant in any of the MAs. This is partly due to the

dominance of the second order  $CD^2$  term in the heavily skewed figure 3.20. The two times that  $CD^2$  is rejected, neither HD or  $HD^2$  is rejected, supporting the belief that the actual distribution of heating and cooling days among the MAs is very different than figure 3.20 suggests.

Because South Florida has a climate that is unique and different from the majority of the rest of the country, none of these temperature variables should be rejected from a study until it can be shown that they are indeed insignificant. In only one instance, a rain variable come close to rejection while the wind variables are, for the most part, acceptable. It must again be noted that lightning in South Florida is very significant and that different regions of the country would have different p-values for different predictors. HD and  $HD^2$  would likely be more significant in Chicago than in Miami, and the wind variables would probably dominate in regions that are incorporating wind farms such as the Midwest.

Disregarding the possible combinatorial effects of the weather parameters, or the occasionally large p-values, the consistent improvement of the  $R^2$  values (whether in isolation or in combination) shows that the modeled equations are valid. Furthermore, it is speculated that the development of new models for the impact of weather conditions on N will provide for better correlations. Another useful study would be to attempt to reveal some of the combinatorial effects by designing a non-linear closed loop (using neural networks). Combining linear modeling (as demonstrated in this document) with non-linear modeling (as suggested for further study), a final model may be constructed. With the high demand for power along with scarce resources, the weather impact on total number of interruptions will be a major point of focus for study in the future.

#### 3.4.4 Design and Risk Assessment for a Predictor

Using three years of daily interruption and weather data, the models presented in [47] were developed. The analysis was performed with statistical and neural network software which led to the development of the models. The data set used included weather and interruption from six management areas (MAs). for approximately 5400 exemplars. A multivariable regression analysis was conducted with the total number of daily interruptions as the target value and the regressors were the total daily rainfall, the maximum two minute sustained wind gust speed and the total daily number of lightning strikes respectively. The other analyses were for function approximation using a one hidden layer back propagation neural network. For both analyses, the same data was used for training to develop a regression equations and to train the neural network. Another set of data called 'test data' were applied to both the regression equation and the trained network. The  $R^2$  was then calculated using the actual number of interruptions as the target value and the predicted number of interruptions by the earlier two methods as the regressors.

The results showed that the trained neural network results were consistently better (in terms of a higher  $R^2$  value). This demonstrates that there are hidden effects that were not accounted for in the regression equation with the raw data.

In the next step the multivariable regression analyses was done using the modified dataset. Around 19 variables were used utilizing all the individual models developed to do regression analyses with the target value being the actual number of interruptions. The same variables and corresponding dataset was used to train the neural network

breadboard. The results from this analyses were that for both the multivariable regression equation and for the trained neural network where the  $R^2$  values were higher.

Figure 3.21 shows  $R^2$  values for the five MAs. The comparison in this figure is done between the statistical analyses using the raw data and the regression analyses done by simulations using the modeled data. The results are that the simulation done with the modeled data shows consistent higher  $R^2$  values as compared to the  $R^2$  values coming out of the analysis with the raw data.

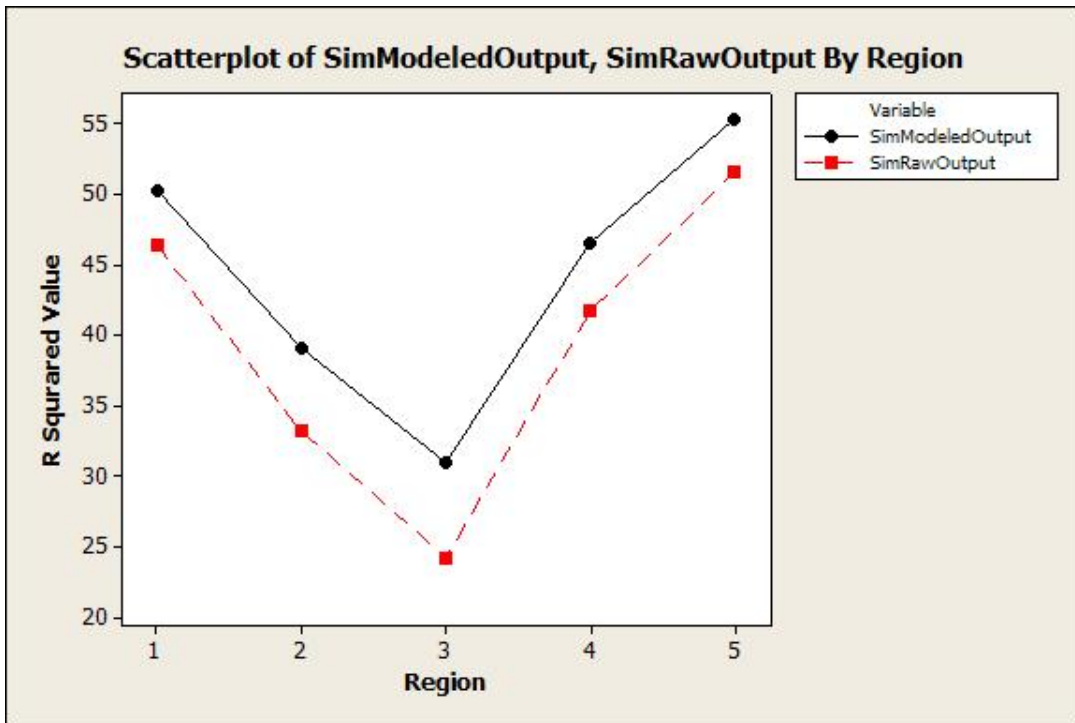

Figure 3.21.  $R^2$  Values of Five Regions

By including barometric pressure as another weather variable, and the recent daily interruption data that reflects the weather trend (system variable), it increases the  $R^2$  values by an average of 50%.



A part of this study was also done by simulating a neural network model using weather data from more than 10 management areas. Although the study took time and recording data at many points became cumbersome; the results were very interesting. It was seen that as we increase the geographic area and try to predict the number of interruptions for the whole region, the accuracy of the system decreases (as expected).

The accuracy of the system improved by increasing the number of rows of data and by reducing the duration of the data collected. The figure 3.22 shows a snapshot of one week of 2008 of actual and the predicted values from six MAs.

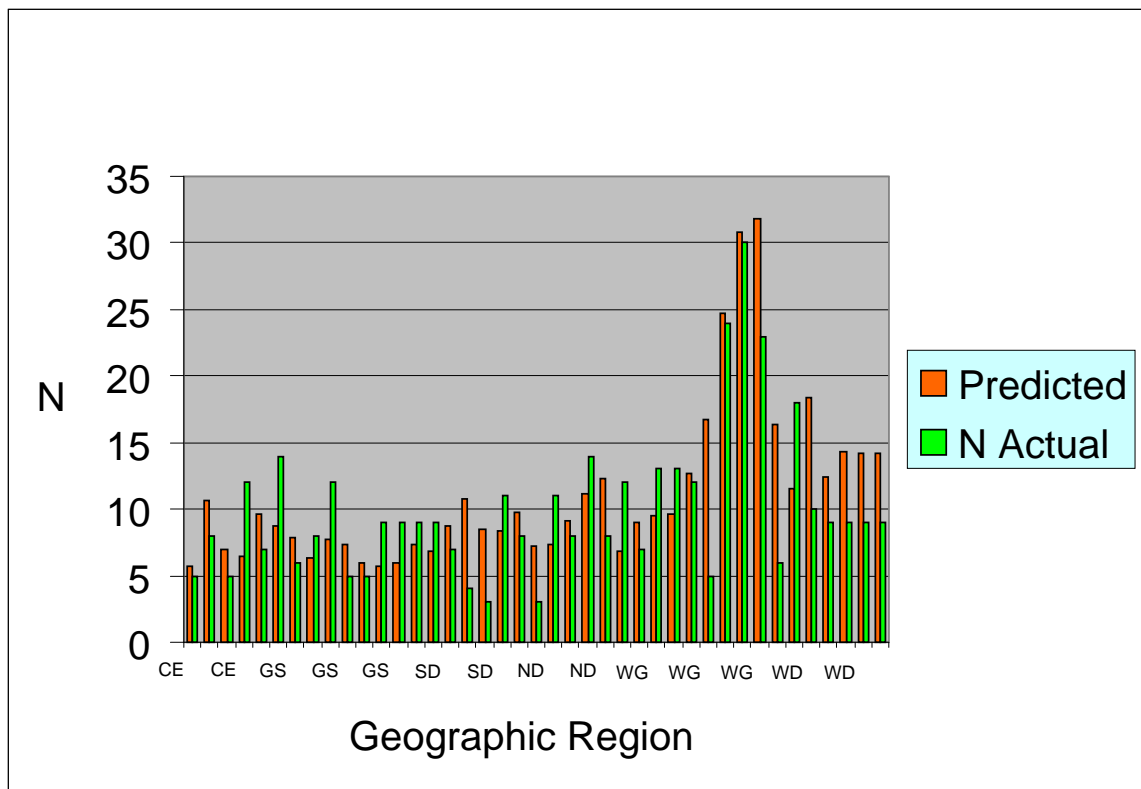

Figure 3.22. Predictor Value vs Actual N for multiple MAs

Another snapshot is given in the form of a histogram in figure 3.23. Given on the left hand side is the actual number of interruptions (N) and on the right is the predicted

number of interruptions. This pattern was similar for all the simulations and the histogram shows results of 4 years of combined dataset with multiple MAs.

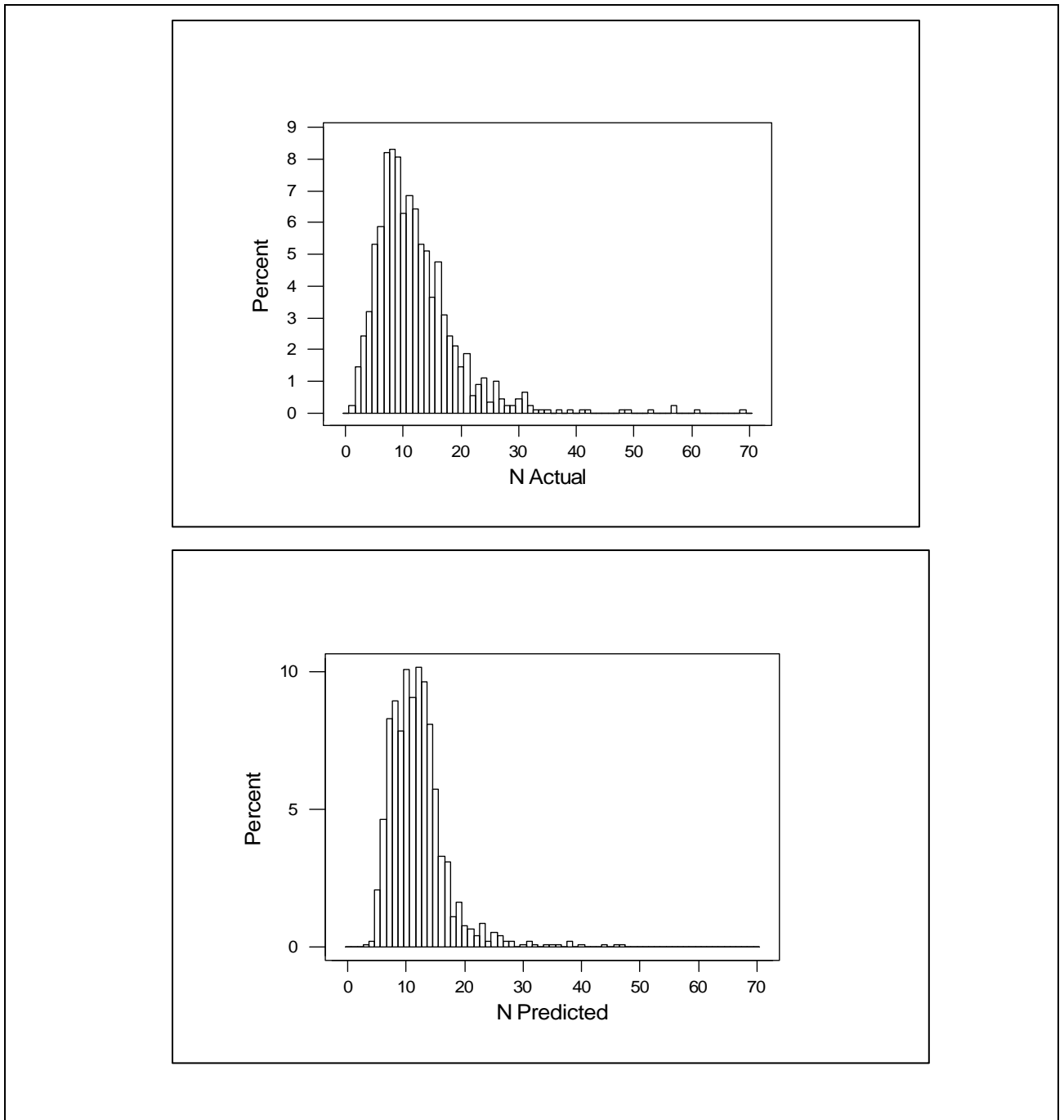

Figure 3.23. Actual and Predicted Numbers of Interruptions

The statistical distribution is similar except that the predictor is predicting a lower number of smaller values as compared to a lower value of actual number of interruptions. This pattern changes if we have a larger dataset to test. Thus, there is remarkable improvement as we keep on adding data to the predictor. A Positive effect on this particular simulation was that the  $R^2$  value returned was 61.3%, which was much higher than what we were getting as in earlier results. This further shows that the size of the data set is extremely important in achieving better results.

Furthering the research, the analyses were done using neural network function approximation. An interesting study was concluded showing that although the predicted value for any given time may not be completely accurate, but a risk assessment calculator can be developed on that basis.

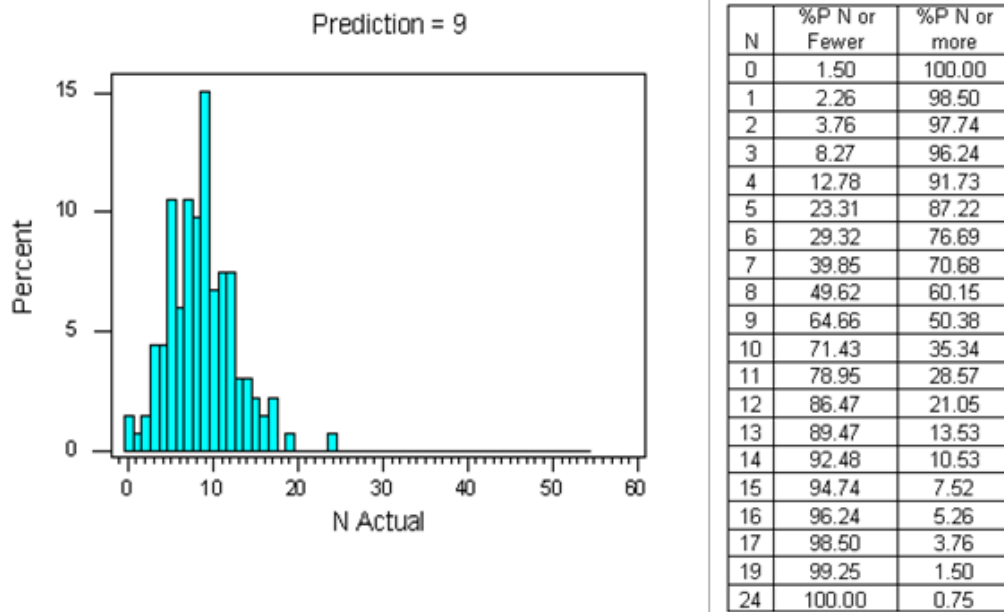

Figure 3.24. Neural Network Function Approximation

Many histogram charts were developed by finding for each value of interruptions predicted, what the actual number of prediction at that instance were. To better explain;

in figure 3.24 a histogram is shown for the days when the predictor predicted ‘nine’ interruptions. The bar of the histogram displays the number of actual interruptions (N) in terms of percentage. On the right side, the cumulative probability is listed based on the actual interruption of the possibility of having up to N interruptions.

From the cumulative distribution chart, it can be seen that if the predictor predicts 9 (nine) interruptions then with more than 92% confidence level, one can state that the number of interruptions won’t be more than 14. This predictor will be a strong tool in the smart grid configuration of modern grid structure. The positive speculations for smart grid are that there will be a predictive and self-healing capability in the grid. Applications like this unique predictor can provide this. Furthermore, risk assessment is a strong tool that can be used by the management to achieve maximum efficiency when planning the amount of long and short-term manpower and equipment inventory. This effort is a patent property of the University of South Florida, Tampa, USA. The predictor Electric Power Distribution Interruption Risk Assessment Calculator (EPDIRAC®) has a USF patent and related software has USF copyrights.

Another unique aspect of this study was to develop methods for benchmarking the dependability of the utilities power delivery service. By normalizing the reliability indices with respect to weather, fair comparisons between the past and present performance of a utility, or between the performances of different utilities, can then be made. Problems that interfere with fair assessments of a system’s reliability, beyond the control of the system operator include: The variability of reliability (and by extension reliability indices) from system to system or from year to year within a system [50]. Thus developing models for the normalization of reliability indices for weather is a necessity.

A thorough literature search has turned up only one methodology for normalizing reliability indices for weather, and that methodology relies on a single weather variable: lightning [51, 52]. Although this methodology is well considered, its application is limited to areas where lightning is the dominant weather variable. In chapter 4, we provide insight to the basic concepts being utilized in this study. A novel method for the normalization of reliability indices is suggested in chapter 5 of this document.

## **CHAPTER 4: SMART GRID RELIABILITY PARAMETERS AND INDICES**

A smart grid consists of variety of power components such as transformers, generators, and overhead lines. The reliability of the smart grid is one of the most important areas of reliability theory application. Random failures are certain to occur from time to time, especially when extremes in weather or other causes present hazards that the power system was not designed to withstand. During these extreme conditions, it is not acceptable that the power system be permitted to collapse and cease operating. Reliability methods also provide important analytical tools that can be used to evaluate and compare smart grid design, breakers, underground cables, and so on. Each component has its unique characteristics. From a reliability point of view, component models are critical to the system reliability. The models should be as simple as possible, but they need to represent all the features, critical, to the system reliability. In this chapter, we will introduce typical reliability parameters, and how they can be modeled [39].

### **4.1 Probability Distribution Functions**

Reliability parameters vary from component to component or from situation to situation. For example, expected repair time is the average repair time of the component considering many failures. After each individual failure, the actual repair time may be lower or higher than the expected value. Because the actual repair time varies, it is

referred to as a random variable. Random variables are represented by probability distribution functions [54,55].

Probability distribution functions transfer a large amount of data to an equation described by few parameters. An associated function to the probability distribution function is the density function,  $f(x)$ , which represents a particular value at which a random variable,  $t$ , will be.

$$f(t) \in [0,1] \quad f\text{- probability density function} \quad (4.1)$$

$$\text{where } \int f(t)dt = 1 \quad (4.2)$$

The integral of the probability density function is cumulative distribution function which reflects the probability that  $f(t)$  will be equal to or less than  $t$ .

$$F(t) = \int_{-\infty}^t f(t)dx ; \text{ where } F = \text{cumulative distribution function} \quad (4.3)$$

A function that combines both the probability density function and the cumulative distribution function is the hazard function,  $h(t)$ . The hazard function is equal to the probability of failure for a component which has not already failed. The density function is the probability of a component failure, and the cumulative distribution function is the probability that it has already failed. The hazard rate can be mathematically expressed as

$$[39]: \quad h(t) = \frac{f(t)}{1 - F(t)} \quad (4.4)$$

Several distribution functions are often used in practical engineering reliability problem calculations. They are divided into [55]:

#### Discrete Distribution Functions

- The Discrete Uniform Distribution

- The Binomial Distribution

#### Continues Distribution Functions

- Normal Distribution
- Lognormal Distribution
- Exponential Distribution
- Gama Distribution
- Weibull Distribution
- Uniform Distribution
- Raleigh Distribution

Presented here are Probability Distribution Functions that are most often used in smart grid reliability evaluation.

#### 4.1.1 Normal Distribution Function

It is characterized by two parameters: Expected Value  $\mu$ , and Variance  $\sigma$ . The formula corresponding to the normal distribution function is:

$$f(t) = \frac{1}{\sigma\sqrt{2\pi}} \exp\left[-\frac{(t-\mu)^2}{2\sigma^2}\right]; -\infty \leq t \leq \infty \quad (4.5)$$

#### 4.1.2 Exponential Distribution Function

The exponential distribution function is the most widely used function in the calculation of reliability in engineering. It is characterized by a constant hazard function, which represents electrical components during their lifetime. Another advantage of the exponential distribution function is that is represented by a single parameter, the expected



value  $\lambda$ . The exponential distribution function is the probability of a component surviving a time  $t$  with a constant failure rate. The formula is:

$$f(t) = \lambda e^{-\lambda t}; t \geq 0 \quad (4.6)$$

#### 4.2 Component Reliability Parameters

Smart grid components can be described by a set of reliability parameters. Sophisticated models use many such reliability parameters. All of the reliability parameters are important, but component failure rates have historically received the highest attention. This is because failure rates have unique characteristics and are essential for all types of reliability analyses. For our research, the simplified reliability models are used based on component failure rates and component repair time.

*The Mean Time to Failure (MTTF).* The parameter that is characterizing the failure process. It is the time to failure, for designated lifetime,  $T$ . It is the time elapsed from zero to the first failure of the component. The  $T$  is a random variable and it is not possible to predict exactly when the unit will fail. However, we can compute the expected value or the mean value [55]:

$$MTTF = m = \int_0^{\infty} t f_T(t) dt; \quad (4.7)$$

Where:

$t$  is the time

$f_T$  is derivative of the failure distribution

*Mean Time To Repair (MTTR).* A repair process can be described the same way as the failure process in terms of a failure distribution and failure density function. MTTR represents the expected time that will take a failure to be repaired (measured from the

time that the failure occurs). MTTR is typically used for each component, but separate values can be used for different failure modes. It is not possible to predict time of repair, so we will compute the mean time to repair:

$$MTTR = r = \int_0^{\infty} tg(t)dt; \quad (4.8)$$

Where:

$t$  is the time

$g$  is derivative of the repair distribution

### 4.3 Component Reliability Data

Electrical reliability data is a very important parameter of the smart grid reliability assessment. It is based on historical utility data, manufacturer test data, professional organizations such as IEEE, and other technical conferences and journal proceedings [54].

#### 4.3.1 Overhead and Underground Lines

Primarily we are focusing on overhead distribution lines that have voltage ratings between 5kV and 35 kV. Overhead lines are directly exposed to variations of weather conditions, vegetation, and animals thus, higher rate of failures are expected. At the same time the overhead lines failure is relatively easy to locate so the repair time is shortened.

The reliability of underground lines and equipment is higher than the overhead lines, primarily because they are sheltered from vegetation and weather. However, the faults are difficult to locate so the repair time is longer.

### **4.3.2 Power Transformers**

Accurate reliability data on power transformers is necessary for evaluating the smart grid reliability. Failure rates depend on the age, size, and type of the transformer ( liquid or dry type) , voltage rating, indoor or outdoor, etc [56]. The mean time to repair of power transformers is very variable.

### **4.3.3 Power Generators**

The generator reliability data is categorized in two major groups: continuously applied and emergency or standby generator units.

## **4.4 Smart Grid Reliability Indices**

Standards like, IEEE Guide for Electric Power Distribution Reliability Indices (IEEE 1366) were developed to summarize reliability indices (see Appendix A). Also, the standards outline the methodologies for calculating these indices, and indicate the factors that affect the calculation of them. The standards define a long interruption as an event where the voltage at the customer's connection drops to zero and does not re-establish automatically. If the interruptions' time is in excess of three minutes then the interruption is referred as a long interruption. An interruption less than three minutes is called a short interruption. These definitions vary from utility to utility and are not accepted as general definitions. Additionally to this, the term "sustained interruption" refers to a longer interruption, ranging from three seconds in IEEE 1159 to two minutes in IEEE 1250 [57].

As mentioned previously, many different reliability indices have been proposed and are being used. They can be divided into four main categories:

- Indices that measure the frequency of sustained interruptions.
- Indices that measure the duration of sustained interruptions.

- Indices that measure the frequency of momentary interruptions.
- Indices that measure the frequency and depth of voltage sags.
- The first two categories have been considered "reliability" issues, while the last two have been considered "power quality" issues. Although there are historical reasons to make the distinction between reliability and power quality, for today's loads the sustained interruptions and momentary interruptions are treated the same.

The main reliability indices used for sustained interruptions (outages in excess of five minutes while excluding major event days) are [57]:

- System average interruption frequency index (SAIFI),
- System average interruption duration index (SAIDI), and
- Customer average interruption duration index (CAIDI).

SAIFI describes how often an average customer will experience a sustained interruption (greater than five minutes). It is defined as:

$$SAIFI = \frac{CI}{N_T} \quad (4.1)$$

where  $CI$  is the number of customers interrupted and  $N_T$  is the total number of customers served for the area.

SAIDI is defined as the total duration of an interruption for an average customer over a specific period. The index is defined as:

$$SAIDI = \frac{CMI}{N_T} \quad (4.2)$$

where *CMI* is the customer minutes interrupted. In terms of load-based indices, the average system interruption frequency index (ASIFI) is often used to measure performance in areas with few consumers and concentrated loads. ASIFI is defined as:

$$ASIFI = \frac{\sum L_i}{L_T} \quad (4.3)$$

where, ASIFI is the ratio of total connected kVA of load interrupted and the total connected kV A served. SAIDI and SAIFI are two of the most common reliability indices used in the industry.

Component reliability data is a very important parameter of the smart grid reliability assessment. In our research, we will use reliability information based on historical utility data, manufacturer test data, professional organizations such as IEEE and other technical conferences and journal proceedings. Electrical equipment reliability data is usually obtained from surveys of individual industrial equipment failure reports. Collection of reliability data is a continuous process and it is constantly updated. The smart grid reliability indices described above are used to quantify sustained interruptions. Short duration outages for some customers, such as hospitals and large industrial customers, can result in complex systems shutting down. These customers usually have a backup generation or other means of addressing short-duration outages. In particular, it is these types of outages would benefit from the presence of distributed generation and energy storage. Therefore, a reliability index must not only quantify enhanced reliability for sustained interruptions, but must also quantify enhanced reliability for short-duration outages.

## CHAPTER 5: NORMALIZATION OF RELIABILITY INDICES

Power companies are constantly striving to improve their reliability performance. The comparison of present performance from past performance is one method that companies use to identify changes in performance. Because of seasonal changes in the weather, these comparisons are often made between the present month and the same month in the previous year. However, because of weather patterns that can shift from year to year, it is difficult to separate the baseline performance from the overall performance. A method of normalizing reliability indices is needed so that engineers can evaluate a system's performance without guessing at the usually highly significant role of weather conditions.

### 5.1 Performance and Reliability Indices

There is already a method being used in Florida, (where the power system under study is located), that can adjust the reliability indices for extreme and catastrophic events - the exclusion. The Florida Public Service Commission (PSC) allows the exclusion of certain interruptions from the calculation of reliability indices including, but not limited to, those "directly caused by...planned interruptions, a storm named by the National Hurricane Center, a tornado recorded by the National Weather Service, ice on lines, a planned load management event, an electric generation disturbance, an electric transmission system disturbance, or an extreme weather or fire event causing activation

of the county emergency operation center” [58]. Interruptions not included in the above definition can be excluded by petition [59].

Another method of normalizing reliability indices has been suggested in [51]. This method is based on the fact that in many areas of Florida, lightning plays a key role in the increase of the number of interruptions (N), and the subsequent increase in other reliability indices. However, there are no methods described that will allow a utility to normalize their reliability indices for the effects of common weather conditions that include rain and wind. Such a method would be useful in areas where lightning does not play as significant a role and during times of the year when lightning is not as common. In addition, modeling the effects of wind, rain, temperature, and lightning on the number of daily interruptions described in [47] has shown that rain and wind will also contribute significantly to degraded reliability.

## **5.2 Baseline Comparison and Other Methods**

Figures (5.1-5.3) show the mean values of total daily rainfall (Rain), number of lightning strikes (LS) and N by month and year for one of the management areas (MAs). A recognizable general pattern can be identified, that of a summer peak in interruptions with a winter falloff, but that it varies from year to year in its specifics. Sometimes the cause of that variation in N can be seen in the weather charts, such as the 2003 N pattern in months 4-9 coinciding with the 2003 pattern of LS, or the 2001 N pattern in months 5-10 corresponding to the 2001 pattern in the Rain figures.

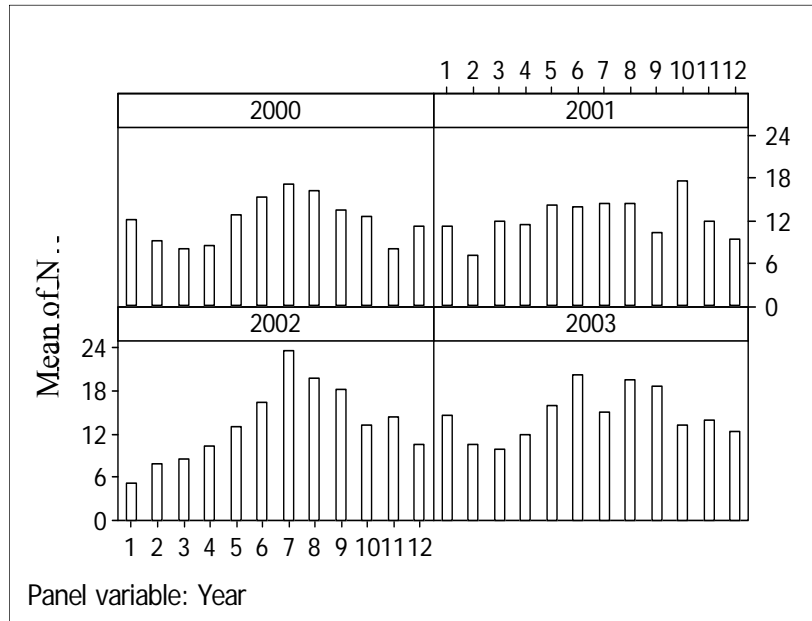

Figure 5.1. Mean of N by Month and Year

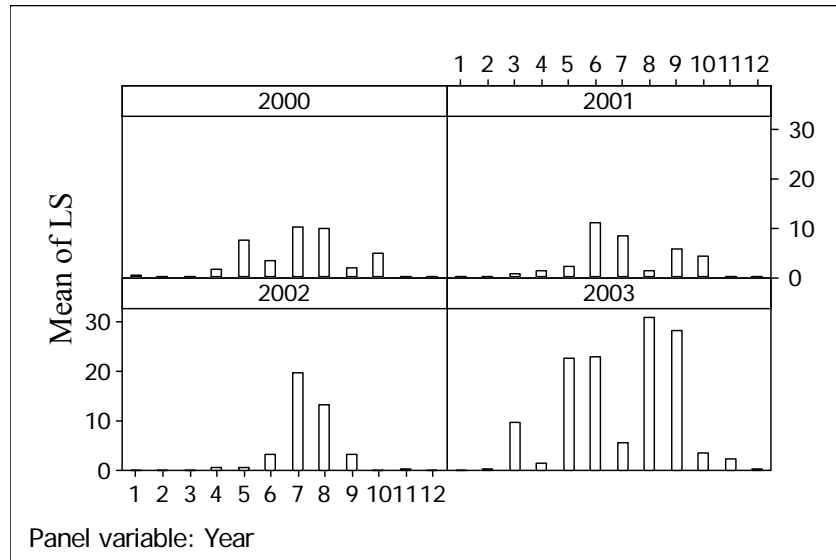

Figure 5.2. Mean of LS by Month and Year



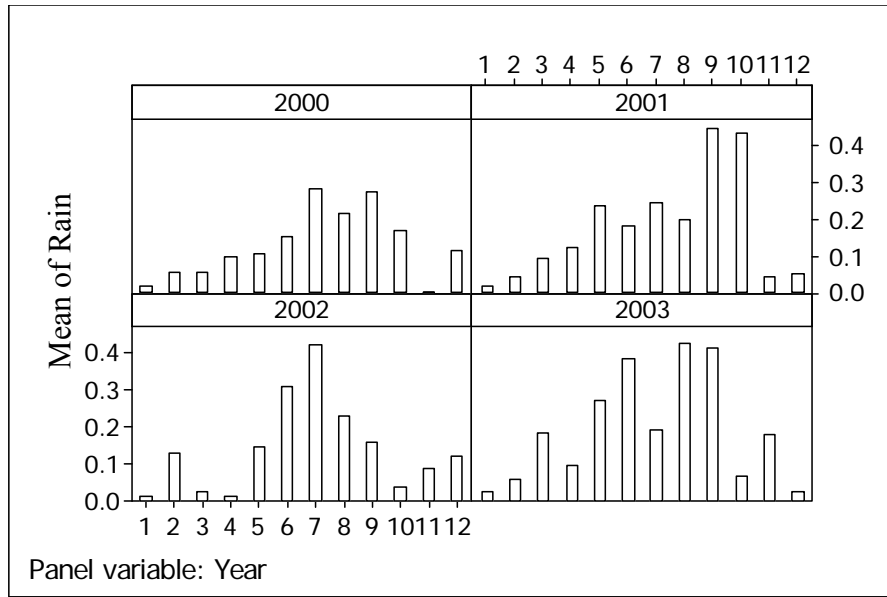

Figure 5.3. Mean of Rain by Month and Year

However, these patterns are difficult to see, are open to debate and provide little useful information. Further, there are other spikes in the figures in which the cause cannot be determined by averages, but may still be due to a single unseasonable event. The one inarguable conclusion that can be drawn from these figures is that reliability indices are subject to shifting seasonal weather variations. Because of the year-to-year variations in monthly averages, reliability reports that do not adjust for variations in seasonal weather patterns would be likely to result in misleading conclusions. The method described in this document finds statistical outliers in both common weather and interruption data, and uses these outliers to identify days where common weather conditions interfere with the evaluation of baseline performance. The reliability indices are then adjusted for use during comparative studies.

Because it is equally likely that the present year could have milder weather and consequently fewer interruptions, this method provides a bilateral analysis with the result that the monthly interruption count, and the associated measures and indices, are equally

as likely to be adjusted up or down. This method simply seeks to even the field so that reliability engineers may focus on other reasons for any shift, up or down, in the reliability indices without the guesswork involved in evaluating the effects of weather.

### 5.3 Assumptions and Statistical Tools

The primary assumption that this method relies upon is that, barring any unusual differences in the operational or environmental conditions that a system experiences, the daily reliability measures should have a high correlation from year to year.

Although there are many reasons that the daily measures may not correlate from year to year, such as improved maintenance, increased under-grounding of overhead conductors, or a majority of equipment reaching the end of their service lives; weather is certainly a significant factor.

The second assumption this method employs is that accounting for the variance caused by any of the above factors, or any others that are not mentioned, will increase the correlation. It is contended in this document that, no matter where in the range the unadjusted correlation lies, if the method described consistently and positively improves that correlation by adjusting the N, associated customers interrupted (CI) and customer minutes interrupted (CMI) counts, then some portion of the effects of common weather have been accounted for. The interpretation of a zero correlation improvement would be that weather patterns did not change.

The statistic of interest for the evaluation of the method proposed in this document is the Pearson correlation coefficient (rho) as given in (5.1).

$$\rho = \frac{\sum_{i=1}^n (X - \bar{X})(Y - \bar{Y})}{(n-1)s_x s_y} \quad (5.1)$$

Where:

- $\bar{X}$  = sample mean for the first variable
- $s_x$  = standard deviation for the first variable
- $\bar{Y}$  = sample mean for the second variable
- $s_y$  = standard deviation for the second variable
- $n$  = number of paired data points

The correlation coefficient measures the strength of the linear relationship between two data sets, has a range of -1 to 1, and is neutral to the means of the variables being correlated.

Another statistic that is often reported for correlations is the p-value. The p-value is a measure of the strength of the correlation; however, confidence intervals have been reported since they provide a measure of the accuracy of the correlation as well as the strength. The confidence intervals for the correlations in this document were calculated by first using the Fisher z-transform. The transformed correlation ( $z$ ) is a standard normal distribution.

$$z = 0.5 \ln \left[ \frac{(1 + \rho)}{(1 - \rho)} \right] \quad (5.2)$$

The confidence limits of  $z$  are found by applying the inverse standard normal distribution function, which does not have a closed form and must be computed numerically:

$$\pm z' = z \pm \frac{NORMSINV \left( \frac{100 - \% \text{confidence}}{200} \right)}{\sqrt{n - 3}} \quad (5.3)$$

The confidence limits for  $z (\pm z')$  are then transformed back to confidence limits for  $\rho$  as shown in (5.4).

$$\rho_{CL} = \left[ \frac{(e^{2\pm z'} - 1)}{(e^{2\pm z'} + 1)} \right] \quad (5.4)$$

Figure 5.4 shows a family of curves for the confidence intervals for  $n$  paired data points between 5 and 1500 with a  $\rho$  of 0.1, 0.5 and 0.9.

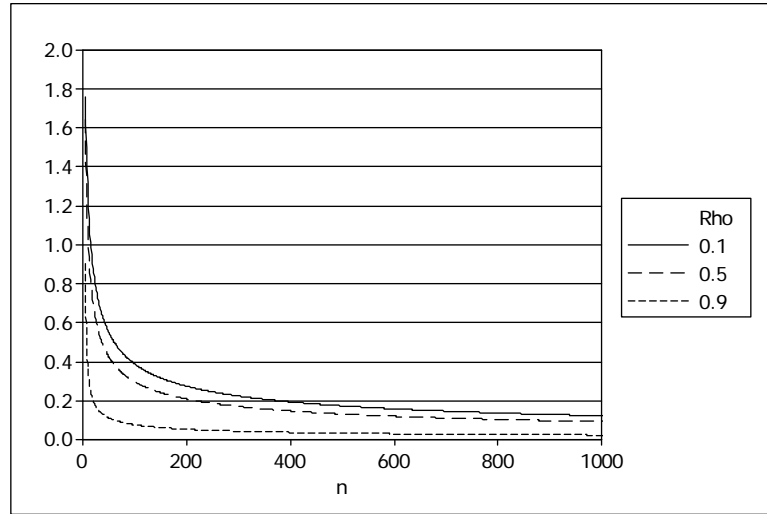

Figure 5.4. Confidence Intervals as a Function of  $n$  and  $\rho$

It is apparent from figure 5.4 that the confidence intervals have inverse characteristics, though non-linearly proportional to both the number of paired data points and the magnitude of the correlation.

#### 5.4 A Novel Method

As was shown in figures 5.1, 5.2, and 5.3, there are seasonal weather patterns that can be seen in the monthly averages, and since this method is intended to find outliers in common weather conditions, comparisons must be made between relatively small samples. Outliers found using an entire year's worth of data would represent extreme weather conditions and would be clustered in the summer and fall months offering little

or no opportunity to normalize the reliability indices year-round. Monthly sampling was chosen because it is a period of time after which comparative reliability studies are often done. It is also a relatively small sample to capture outliers that would otherwise be lost.

However, in Florida, occasionally, there are months where the number of days reporting non-exclusionary interruptions is much less than 30. August and September of 2004 are such months, reporting less than eight days each month due to back-to-back hurricanes. These months were not included in the analysis and would not have benefited from normalization at any rate. Therefore, the total number of months normalized from 2001 through 2004 is 46.

For these reasons, monthly sampling provides the most accurate comparison of one year's common weather conditions to another year's common weather conditions. Since 1981, there has been a program to build Automated Surface Observation Stations (ASOSs) at airports throughout the US. These stations were primarily intended as a weather data source for aviators, but have since turned out to be the best source of historical surface weather data in the US. Since 1996, the National Climatic Data Center (NCDC) has been making ASOS data available as an online download. This data includes daily and hourly summaries in ASCII format from every ASOS in the country.

Five years of daily summary ASOS data (2000-2004) was collected from the NCDC for weather stations located within or near nine MAs in the area of study. The value for wind was chosen to be the 2-minute maximum sustained gust (2MMaxS) and for Rain, total daily accumulation.

One of the largest utilities in Florida provided N and LS data from their records for the MAs of interest. Because this method is designed to normalize reliability indices

for common weather conditions, the N data was segmented to exclude interruptions that were either administrative in nature (tickets written in error, no loss of service (NLS), etc) or that were deemed exclusionary by the PSC as described in the introduction. Further, many of these exclusionary interruptions were due to extreme weather conditions, such as hurricanes, that require the exclusion of the entire day's interruptions. In the latter case, the weather for that day in that MA was also excluded from the calculation of the weather outlier limits.

In terms of bilateral analysis, weather and interruption data was compiled for five years for nine MAs, and four separate studies were performed for each MA. An example of a study performed is 2001 versus 2002 with 2002 being the year that is to be adjusted. In this case, 2001 was initially used as a reference year, providing the outlier thresholds that the 2002 weather was compared against, and then the analysis was reversed with 2002 as the reference year and 2001 as the target year.

Weather outliers were identified as those days in the target years that had weather values above the reference outlier limits. All outliers were tabulated, and those days that had interruptions greater than the N outlier threshold for the month, that also occurred on the same days as one or more weather outliers, were defined as intersections.

The determination of how much the 2002 N would have to be adjusted was made daily, by subtracting the 2002 interruptions that were found to be related to a weather outlier (defined by the 2001 outlier limits), and adding the 2001 interruptions that were found to be related to a weather outlier (defined by the 2002 outlier limits). In this manner a bilateral analysis was achieved that allowed for the possibility that the 2002 weather was much milder than the 2001 weather and that the 2002 N would subsequently

have to be increased in order to perform a comparative reliability study that was not skewed by variable weather patterns.

This study compared four daily values: N, 2MMaxS, Rain, and LS. The following discussions of the shapes of the data sets and the distributions they most closely resemble provide the rationale for the choice of thresholds beyond which we determine that a data point is an outlier. Histograms and probability plots of the actual data will be used to show the fit of the data to the distribution chosen to model it.

The following figures and plots are representative of all the ASOSs and MAs. Interruptions (N): It is well known that interruption data (N) follows the lognormal probability distribution and have been verified using probability plots of the data provided. The data must first be transformed by taking its natural log. The transformed data will follow a normal distribution, so to determine the threshold above which the target data will be compared to the weather outliers, the mean, plus some number of standard deviations of the transformed target data, the following equation was used:

$$\text{Threshold} = \alpha + A\beta \quad (5.5)$$

Where  $\alpha$  is the mean of the transformed target data,  $\beta$  is the standard deviation of the transformed target data, and A is the number of standard deviations wanted. This transformation and the associated threshold calculations are performed on the target data.

The wind data defined by the 2MMaxS is most closely modeled by the Largest Extreme Value, or the Gumbel (maximum case) probability distribution. A probability plot of the 2MMaxS data is shown in figure 5.5. It should be noted that the 2MMaxS data is limited to integer values, thus it cannot be made to fit as well as a randomly generated

Gumbel distribution, although the fit is quite good for a naturally occurring data set as can be seen by the Anderson-Darling value of 2.22.

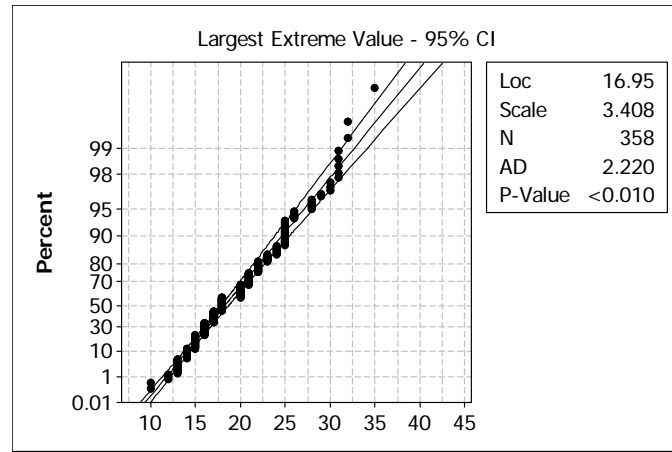

Figure 5.5. Probability Plot of 2MMaxS Data

The procedure used to find the outlier threshold is as follows. The location and scale parameters of the 2MMaxS data,  $\mu$  and  $\beta$  respectively, must first be estimated from the reference data. The equations for estimating these parameters are as follows.

$$\mu = \bar{X} - 0.5572\beta \quad \text{and} \quad \beta = \frac{s\sqrt{6}}{\pi} \quad (5.6)$$

Where  $\bar{X}$  and  $s$  are the sample mean and standard deviation of the reference data respectively.

For this distribution, unlike the normal or lognormal distributions, there is a closed form percent point function. The percent point function is the inverse of the cumulative probability function in that it calculates the probability that a member of the data set is greater than or equal to  $x$  for a given  $x$ . The percent point function is given in (5.7).

$$G(p) = -Ln\left(Ln\left(\frac{1}{p}\right)\right) \quad (5.7)$$



Where  $p$  is the percentage under the curve expressed as a fraction of one. A 0.9 percentage, meaning that 90% of the data will be under the curve at that percent point, can be calculated as a 2.25037 percent point ( $G(p)$ ). This is a fixed value, independent of the location and scale parameters.

To apply this function to the target data, the target data must first be standardized using the location and scale parameters,  $\mu$  and  $\beta$ , of the reference data. However, it is not necessary to transform the reference data, merely calculating the location and scale parameters of the reference data. The location and scale parameters of the reference data can then be used to standardize the target data using the following equation.

$$G(x) = \frac{(x - \mu)}{\beta} \quad (5.8)$$

Following this standardization, approximately the top 10% of the data, depending on fit, will be greater than or equal to 2.25037. By using the location and scale parameters of the reference data to standardize the target data, shifts in the range of values, which may occur due to annual variations in weather patterns, will be transferred to the standardized data. Then the outlier threshold will be 2.25037. Figures 5.6 and 5.7 illustrate how the data will shift using the prior year's parameters.

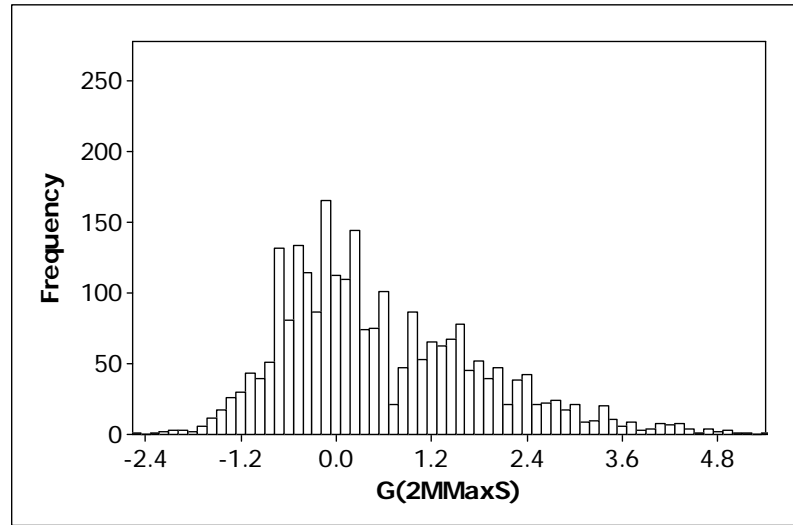

Figure 5.6. Histogram of 2003 Standardized 2MMaxS Data

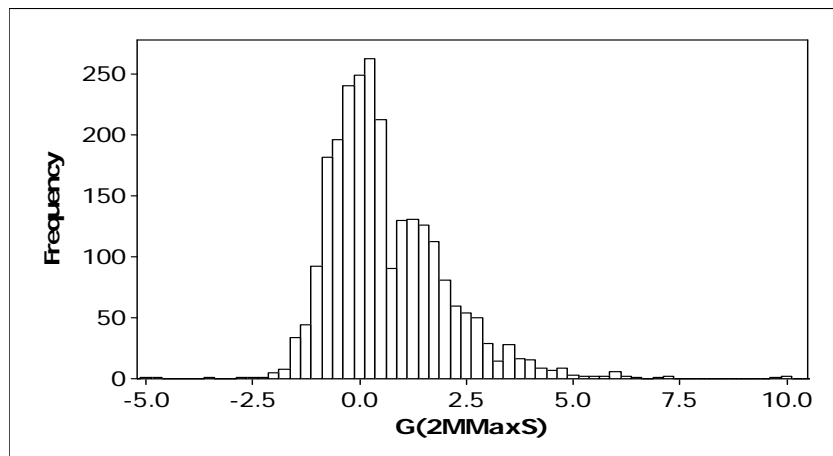

Figure 5.7. Histogram of 2003 2MMaxS Data Standardized with 2002 Location and Scale Factors

Although this seems more complicated than the lognormal transformation, it is actually simpler because the percent point function is in closed form, and the outlier threshold is fixed.

The Rain and LS data did not fit any of the standard distributions because a large percentage of the data was zeros. The remainder of the data had, as a general

characteristic, a heavy grouping of data points at the lower values with individual extreme values spread across a large range.

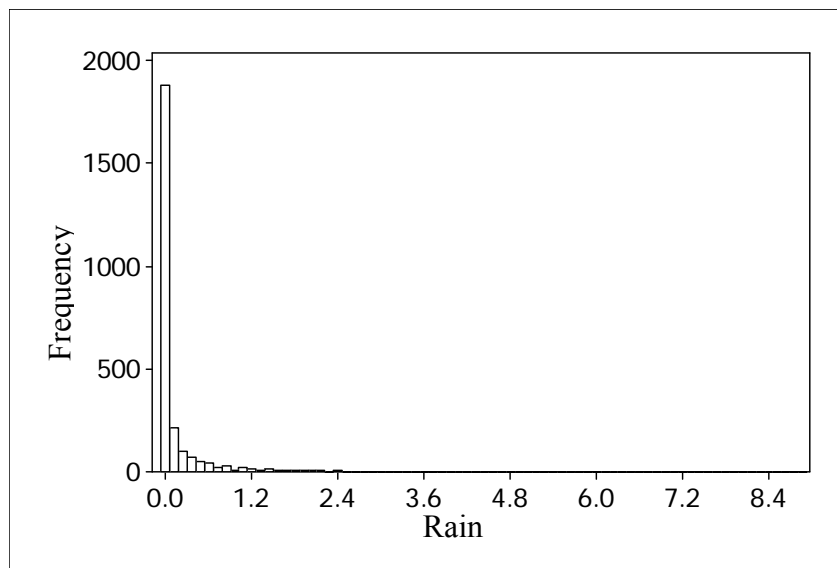

Figure 5.8. Histogram of Rain

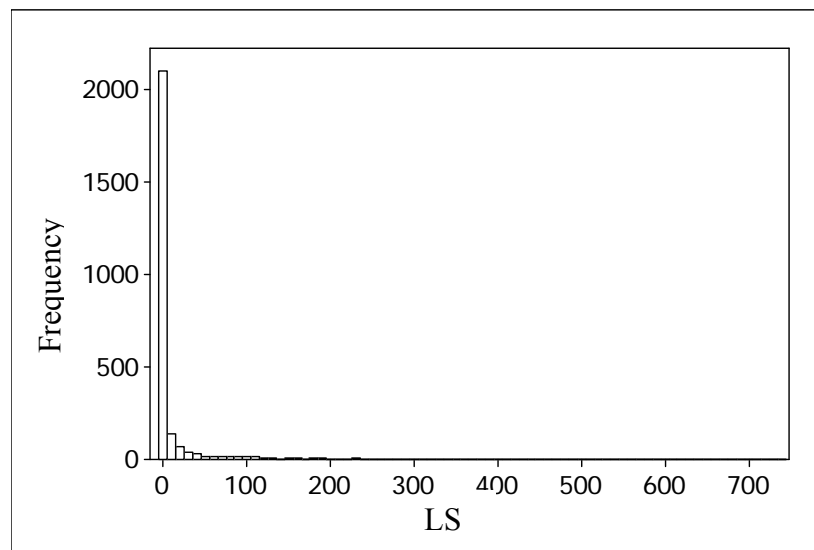

Figure 5.9. Histogram of LS

Figures 5.8 and 5.9 show the distribution of the data. Because of the large Y scale, there are many individual data points on the X scale that cannot be shown, but an idea of the shape of the data can be developed by observing that the X scale is limited by the

largest value in the datasets. Because of the fact that no distribution could be found to fit the data, Tchebysheff's Theorem was used to estimate the outlier limits. Tchebysheff's Theorem [5] states that for a certain number, K, of standard deviations, a certain minimum percentage of data points will always fall within plus or minus the mean plus K standard deviations regardless of the distribution. The following equation gives that percentage and can be solved for any number K, with K not limited to integer values.

$$\text{Percentage} = \left(1 - \frac{1}{K^2}\right) \quad (5.9)$$

Although this equation defines the maximum number of standard deviations required for a specific percentage of the data to be under the curve, the actual number of standard deviations must be determined empirically.

The choice of outlier thresholds for the variables in this method cannot be determined definitively, but must be approached heuristically. A theoretical basis combined with an empirical application provides the choices with optimal results. An outlier threshold that is generally accepted is the mean plus three standard deviations of a normal distribution which puts approximately 99.77% of the normally distributed data under the curve. This provided a basis for the choices for the thresholds for the Rain and LS reference data. The Rain and LS distributions in Figures 5.8 and 5.9 suggest that even at that level, the most damaging days will still be captured. Additionally, there are many months with very little or no Rain or LS, in which case the location and scale factors applied to the target data would both be zero, effectively making any day with Rain and/or LS an outlier. Direct experimentation showed that the optimal thresholds were nearly the same as the normal mean plus three standard deviations.

Wind has a cubic relationship with the number of interruptions [47], [53] and after approximately a 25 mph 2MMaxS the effect is magnified substantially. The use of the 99.77% standard for a 2MMaxS outlier would set the threshold at over 35 mph, effectively eliminating many possibly extreme damaging wind values. Furthermore, the weather data is taken at a point source and the interruption data is taken from an area source. As such, the 2MMaxS was considered an indicator of the wind conditions for that day rather than a definitive value. The threshold was chosen so that lower values could be captured.

The threshold for the interruption data, N, was chosen to be the mean plus 0.8 standard deviations of the log transformed target data. Since the location and scale factors of the N data apply to the target data, it was determined that the upper 20% of the N data should be available for comparison with the weather outliers that are defined by the location and scale factors of the reference data. The purpose of this is to allow for those days that have a high number of interruptions whose causes are not related to the weather. Further, a high threshold would limit the effectiveness of the method by denying the ability to cross-correct (when several days in the same month have both positive and negative adjustments, thereby canceling).

Table 5.1 shows the location and scale factors (or percentage point) chosen and the percent of the data that is under the curve when the location and scale factors are applied to the data from which they are derived.

Table 5.1. Location and Scale Factors

	Rain	Wind	LS	N
Location and Scale	$\mu+5.15\sigma$	$G(p)=2.00$	$\mu+5.15\sigma$	$\alpha+0.8\beta$
Percent Under Curve	99.67	86.23	99.11	79.82

### 5.5 Effectiveness of Results

Five years (2000-2004) of both interruption and weather data were collected with the first year having its measures adjusted (2001). For the four years when measures were adjusted (2001-2004), there were approximately 1,350 (allowing for missing data) paired data points available for correlation in each MA for each measure. Figures 5.10, 5.11, and 5.12 and Table 5.2 show the correlation improvements for each daily measure. For maximum clarity, the data has been sorted from the lowest post-adjustment  $\rho$  value to the highest.

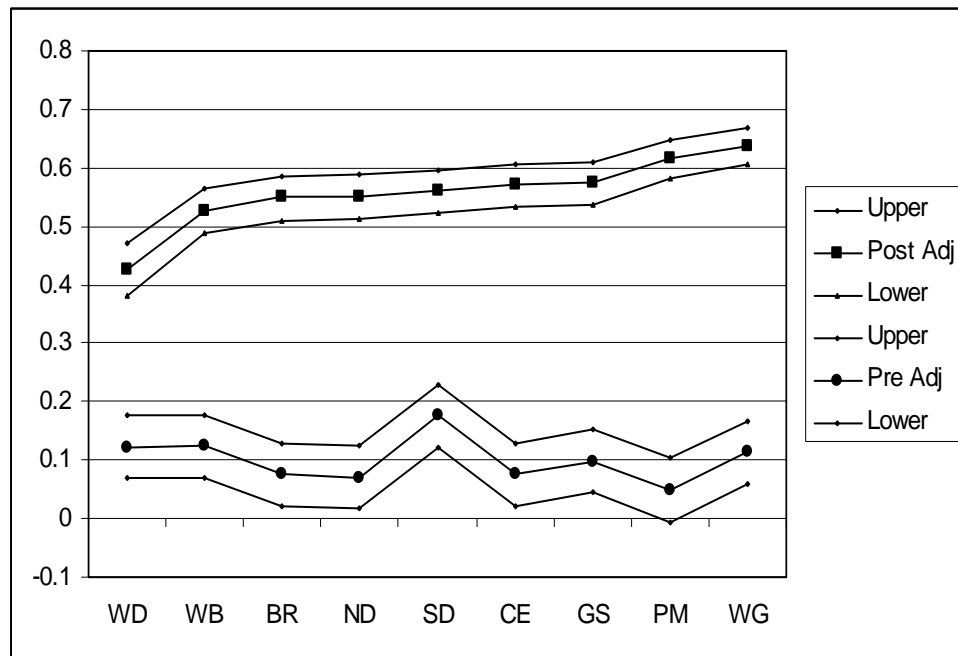

Figure 5.10. Pre and Post Adjustment  $\rho$  by MA for 4 Years Daily N with 95% Confidence Intervals

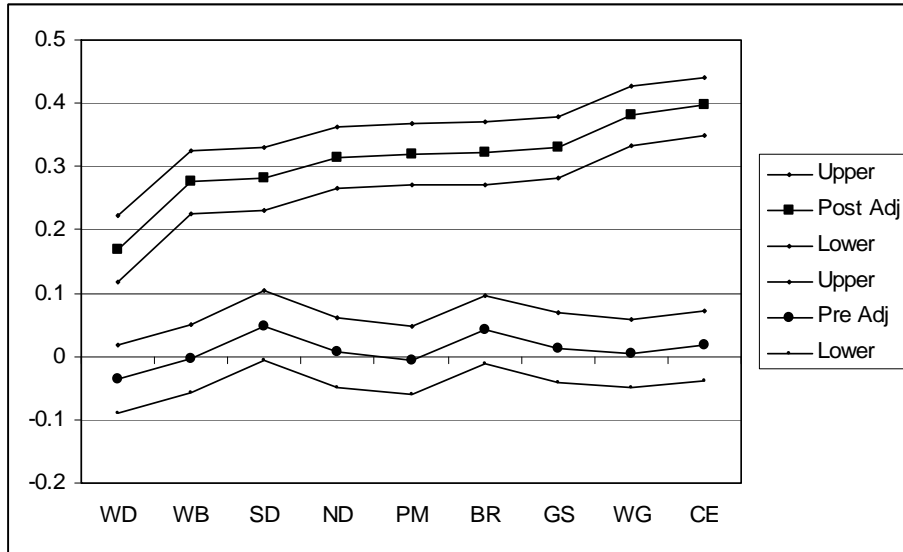

Figure 5.11. Pre and Post Adjustment  $\rho$  by MA for 4 Years Daily CI with 95% Confidence Intervals

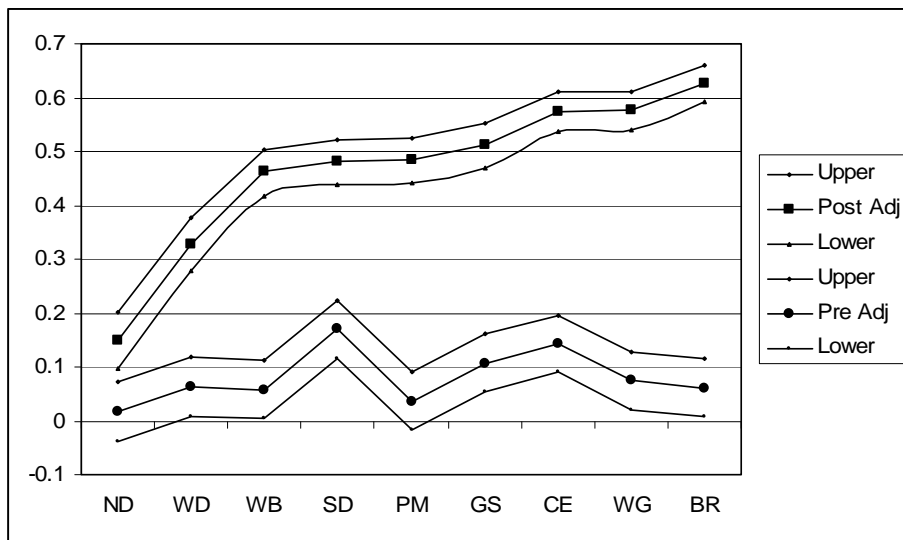

Figure 5.12. Pre and Post Adjustment  $\rho$  by MA for 4 Years Daily CMI with 95% Confidence Intervals

Table 5.2. Overall Improvements in rho

n≈1350 Avg. 95% Confidence Interval $\approx \rho \pm 0.048$			
	N	CI	CMI
Maximum	0.567	0.380	0.566
Average	0.457	0.301	0.385
Minimum	0.303	0.205	0.133

It can be seen from figures 5.10, 5.11, and 5.12 and Table 5.2 that in each case, the adjustments performed by the proposed method resulted in a medium to strong improvement in the linear relationship between the two years' daily measures. It can also be seen that for most of the trials, there was either little, none, or negative linear relationship between the two years for CI. A discussion of correlation coefficients requires some way to characterize their absolute, or in the case of comparisons, relative magnitudes. A general rule of thumb for magnitude characterizations is shown in Table 5.3.

Table 5.3. Correlation Magnitude Characterizations

0.0-0.1	0.1-0.3	0.3-0.5	0.5-0.7	0.7-0.9
Clinically Trivial	Small	Moderate	Large	Very Large

It can be seen by applying these characterizations to the correlation improvements shown in figures.5.10, 5.11, and 5.12 and Table 5.2 that the improvements in the adjusted measures range from small to large with a moderate average. It can also be seen that the correlations of the unadjusted measures is small or for the most part, clinically trivial. It is reasonable to assume, based on these results, that the use of the adjusted measures to



calculate the reliability indices N, SAIFI, SAIDI and CAIDI should result in a stronger linear relationship between one year's reliability indices and the next year.

However, because the reliability indices are calculated monthly, the number of months in this dataset for each MA is only 46, and referring back to figure 5.4, it can be seen that for moderate to large (using the  $\rho=0.5$  curve) correlations the number of paired data points needed to attain a confidence interval of 0.10 is approximately 850. While confidence intervals for an n of 46 would be approximately 0.45 for the adjusted indices and 0.55 for the unadjusted indices. figure 5.13 shows the correlations and confidence intervals for Monthly SAIFI.

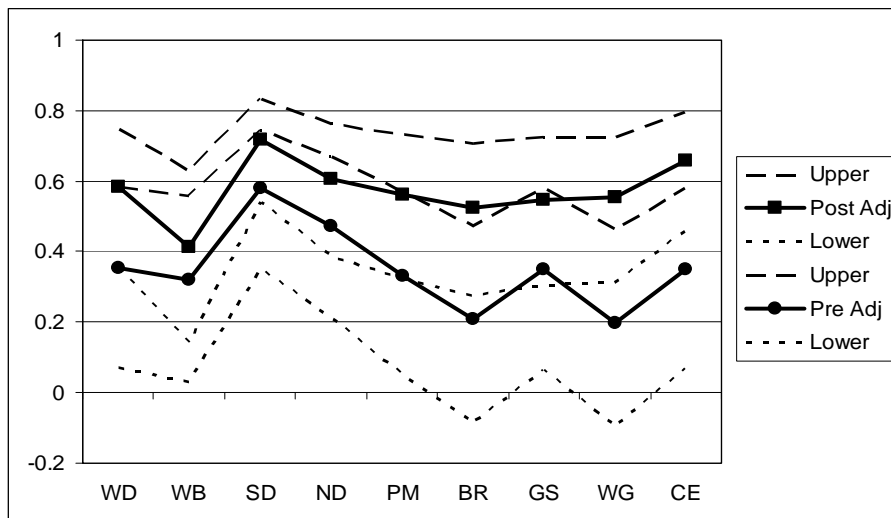

Figure 5.13. Pre and Post Adjustment  $\rho$  by MA for SAIFI for 46 Months with 95% Confidence Intervals

It can be seen that, although there is a consistent improvement in  $\rho$ , such large confidence intervals overlap not only each other, but also the correlations themselves, so that the correlations cannot be used for comparison. As n goes down, the confidence intervals increase rapidly, so this type of analysis can produce erroneous results if

performed with a smaller n than is required to attain confidence intervals that do not overlap.

## **5.6 Assessment and Limitations**

The limitations of this method can be attributed to the bilateral nature of the analysis and of the data required. Because this method compares one year to another by finding outliers in the monthly data, the averaging of many years' weather and interruption data would obscure the very outliers that this method depends on, so comparing a multi-year average could not be done by averaging the raw data. In addition, a multi-year analysis of reliability trending could not be done because each year is normalized to only the previous year's raw data rather than its own normalized data. However, both of these types of analysis could be done by establishing a baseline year for normalization and averaging or trending the following years' normalized reliability indices.

The weather data used is generated by ASOSs located at airports around the country. Although ASOSs are the most prevalent type of weather station available publicly, there are other types available. However, not every locale will have an available weather station and only the ASOSs have the range of data used in this analysis. This limitation can be overcome by installing dedicated weather stations in the area of interest.

If a recording of a single month's behavior of a power system and the operational and environmental conditions were taken, and was repeated endlessly without any change in the operational or environmental conditions, then the behavior of the system for any month would have a one-to-one correlation to the first month's behavior. As changes in the operational or environmental conditions were introduced, that correlation would be

reduced. However, by accounting for some of those changes and adjusting the later behavior of the system, the correlation with the first, or baseline, month would be brought closer to the initial one-to-one.

The proposed method has been shown to consistently and positively improve the correlations between the present year's reliability measures and the previous year's reliability measures. Since the adjustments were done solely on the basis of daily weather values, accepting the logic in the above argument, it can be concluded that at least some part of the effects of weather on the reliability measures N, CI and CMI have been accounted for, and that the measures have been normalized for weather. Because the reliability measures have been normalized for common weather conditions, and reliability indices are calculated from these measures, it can be concluded that the reliability indices have been normalized as well.

Several aspects of the future work focus on the refinement of the accuracy by which interruptions are captured for adjustment. It is expected that many of the interruptions that have been captured for the analysis that has been presented, are not associated with the weather. This could be due in part to the fact that the daily weather values represent maximums and totals in part of the fact that some of the interruptions captured are due to causes that are not sensitive to the weather. It can be concluded from this that the adjustments may be significantly lower than what is needed to account for all of the variations in the weather.

The interruption data used for the analysis presented in this document includes all interruption causes. In all probability, however, not all interruption causes are sensitive to weather, and some, such as animal activity, may have negative correlations. For this

reason, this method will be applied to the same datasets as used here, except the data will be segmented by an interruption cause.

The results of adjusting reliability measures by cause codes and then combining for a total adjustment are expected to provide normalization that is more accurate. As a secondary benefit, the ability to identifying those causes that are most sensitive to the weather will be available. Temperature data was not used in this analysis, although it has been shown to have a definable relation to the number of interruptions [45]. The inclusion of additional weather variables, such as snow and ice, will have to be performed when data from a utility where these conditions occur becomes available.

Because the weather data used was collected by ASOSs that were constructed for the FAA, the data is not always centrally located within an MA, thereby reducing its accuracy. SG has been installing dedicated weather stations in locations central to their MAs. When sufficient historical data has been collected, trials of this method will be performed using that data. The use of SGs weather data will improve the geographical reference of the weather data.

Although the results shown above are encouraging, further research needs to be done to determine the optimal outlier thresholds, additional variables that should be included, and to verify that the model produces consistent results through repeated simulations using different data sets. A method of normalizing the reliability indices between systems will be developed employing the models used above. Additional variables will be determined that will address the variations in the climate that different systems experience.

In the following chapters, we would try to calculate the availability of the system configured with smart grid technologies including renewable distributed generation. This is a unique situation because smart grid applications are taking place as we write this document. Research of such kind has never been explored due to current implementation of changes to the existing grid.

## CHAPTER 6: MODELING METHODS FOR SMART GRIDS

The smart grid technologies are expected to change the fundamental design and operating requirements of the electric distribution system. A number of topics to understand and analyze this issue have been identified. They can be grouped in the following categories [60]:

- The need for current analysis tools to evolve and address a new, more interactive distribution system of the future.
- Change and upgrade to distribution engineering tools to simplify their use and more efficiently handle distributed and renewable-generation-related issues.
- Develop new analytical methods and related tools to determine the effects of high-penetration distributed generation on capacity limits.
- Develop cost and benefit evaluation tools that better define the relationship of distributed resources to power system operations and dispatching.
- Identify and document modeling and specification requirements for smart grid interconnection equipment.

The primary engineering tools are power flow and fault-current studies. A power flow computes steady state voltages and current of the systems ensuring that the system will meet important criteria such as equipment loading, voltage drops and system losses. While the power flow modeling can predict the electrical properties of smart grid,

reliability modeling is predicting the availability and interruption of such a system. In general, smart grid engineering tasks can be divided into planning and design stages [61]. The planning function is to identify system needs and limitations, to propose projects, to resolve the issue, and to gain approval for projects. The design function takes a project from concept to realization in a safe, efficient and cost-effective manner. Primary planning functions are:

- Load flow
- Reliability assessment
- Distribution impacts screening
- Installation database management
- Assessment of grid-level impacts

Reliability assessment is an ever evolving issue of increasing importance.

Planning function that enables reliability modeling are [62]:

- Design new system to meet reliability target
- Identify reliability problems on existing systems
- Design system that can offer different levels of reliability

In this chapter we introduce modeling techniques and methods for analysis of smart grid reliability.

### **6.1 System Modeling and Analysis**

Reliability of the power system has been of great interest since the early days of the establishment of the power system structure. There are many reliability techniques used in power system analysis. With the introduction of smart grid technologies to the power systems, the previously developed techniques and models, cannot be used for

reliability analysis, because of the new dynamics. To analyze smart grid new methods need to be developed. The base methods that we will be using for the development of the new method will be introduced here.

### **6.1.1 Markov Modeling of Smart Grid**

Markov modeling is a method based on the system states and transitions between these states. Two assumptions are made for Markov models:

- The system is memory less, which means that the future probability of events is only a function of the existing state, disregarding what has happen prior the system entering this current state.
- The system probability between the states is constant. The probabilities are not a function of time.

Markov modeling can be either discrete or continuous. The discrete Markov modeling is called the Discrete Markov Chain, while the continuous is called a Continuous Markov Process [39]. In this research we are modeling smart grid reliability with a Continuous Markov Process.

A Markov Process is described by the set of states and transition characteristics between these states. The state transitions in a Markov Process occur continuously. Instead of state probabilities, Markov Processes use state transition rates. This is very suitable in the application of smart grid reliability, because the failure rates of the smart grid components are equivalent to the state transition rates. In order to be able to use Markov modeling, the failures of the smart grid components' equipment are assumed to be exponentially distributed, so the failure rates are constant. Also the other values such as: switching rate and repair rate are within exponential distributions. The failure rates,



the switching rates and the repair rates are a reciprocal of the Mean Time to Fail (MTTF), Mean Time to Switch (MTTS) and Mean Time to Repair (MTTR).

$$\begin{aligned}\lambda &= \frac{1}{MTTF} \quad ; \text{ failure rate} \\ \sigma &= \frac{1}{MTTS} \quad ; \text{ switch rate} \\ \mu &= \frac{1}{MTTR} \quad ; \text{ repair rate} \quad (6.1)\end{aligned}$$

Markov modeling can be used in a general form that is applicable to any size and complexity. The state probabilities or state transition rates can be computed using matrix differential equations, which can then be constructed using the following rule [55].

$$\begin{aligned}\frac{dp_i(t)}{dt} &= \dot{p}_i(t) = (\text{inflow to state } i) - (\text{outflow from state } i) \\ &= \sum_{j \neq i} (\text{rate of transition to state } i \text{ from state } j) \times p_j \\ &\quad - \sum_{j \neq i} (\text{rate of transition from state } i \text{ to state } j) \times p_i\end{aligned} \quad (6.2)$$

Where  $\dot{p}_i(t)$  = probability of system state  $i$  at time  $t$ . Equation (6.2) can be written in matrix form:

$$\dot{\mathbf{p}} = \mathbf{T}\mathbf{p} \quad (6.3)$$

The solution of this vector differential equation is:

$$\mathbf{p}(t) = \mathbf{p}_0 e^{\mathbf{A}t} \quad (6.4)$$

where  $\mathbf{p}_0$  = a vector of initial conditions of all states. The exponential equation (6.4) absolutely and uniformly converges in a finite time interval [64]. Common practice is to

assume that the state where all components are UP with a unity probability while the others have zero probability

$$e^{At} = I + At + A^2 \frac{t^2}{2!} + \dots = I + \sum_{k=1}^{\infty} \frac{A^k t^k}{k!} \quad (6.5)$$

In our case, we are interested in the final value of the state probabilities. In this case, derivatives of the equation (6.3) will be zero, so we will have a system of algebraic equations:

$$\mathbf{0} = \mathbf{T}\mathbf{p} \quad (6.6)$$

Determinant of  $\mathbf{T}$  is zero, which means that the equations are not linearly independent.

However, we can discard one of the equations and substitute the equation

$$\sum_{i=1}^n p_i = 1 \quad (6.7)$$

Since we know that the sum of the state probabilities is a certainty [55]. We can write the transition matrix in the form:

$$\mathbf{T} = \begin{bmatrix} t_{11} & t_{12} & \dots & t_{1n} \\ t_{21} & t_{22} & \dots & t_{2n} \\ \dots & \dots & \dots & \dots \\ t_{n1} & t_{n2} & \dots & t_{nn} \end{bmatrix} \quad (6.8)$$

The off-diagonal elements of  $\mathbf{T}$  are the failure rate and repair rates that represent the transitions between the states of the system. The diagonal elements represent the transitions out of the states with a negative sign. If we substitute equation (6.7) for the  $n$ th -row of the  $\mathbf{T}$  matrix, we will get a new equation for the transition matrix :

$$\mathbf{T}_n = \begin{bmatrix} \mathbf{t}_{11} & \mathbf{t}_{12} & \dots & \mathbf{t}_{1n} \\ \dots & \dots & \dots & \dots \\ \mathbf{t}_{(n-1)1} & \mathbf{t}_{(n-1)2} & \dots & \mathbf{t}_{(n-1)n} \\ \dots & \dots & \dots & \dots \end{bmatrix} \quad (6.9)$$

We can write the new steady-state equation as:

$$\begin{bmatrix} \mathbf{t}_{11} & \mathbf{t}_{12} & \dots & \mathbf{t}_{1n} \\ \dots & \dots & \dots & \dots \\ \mathbf{t}_{(n-1)1} & \mathbf{t}_{(n-1)2} & \dots & \mathbf{t}_{(n-1)n} \\ \mathbf{1} & \mathbf{1} & \dots & \mathbf{1} \end{bmatrix} \begin{bmatrix} \mathbf{p}_1 \\ \dots \\ \mathbf{p}_{n-1} \\ \mathbf{p}_n \end{bmatrix} = \begin{bmatrix} \mathbf{0} \\ \dots \\ \mathbf{0} \\ \mathbf{1} \end{bmatrix} = \mathbf{b} \quad (6.10)$$

where the right hand side  $\mathbf{b}$  is no longer zero. The final solution of the steady state condition is:

$$\mathbf{p} = \mathbf{T}_n^{-1} \mathbf{b} \quad (6.11)$$

which will give a probability of every state in the system.

### 6.1.2 Modeling of the Smart Grid with a Boolean Logic Driven Markov Process

(BDMP)

Smart grid will allow current electrical grid to better incorporate renewable energy sources such as wind and solar power, back-up distribution generators and advanced energy storage systems. Reliability modeling of smart grid raises difficulties due to dynamic reconfigurations of the system. The problem can be modeled using Monte Carlo simulations, but obtaining good precisions is very time consuming when the system is large and dynamic [66, 67, 68]. To solve the modeling problems, we will use new formalism which combines the Boolean logic of Fault tree technique and Markov Process [69, 70, 71]. This modeling approach has advantages over conventional models because it allows complex dynamic models to be defined and still remain easily readable.

The purpose of BDMPs is to provide a new graphic representation of fault trees, augmented only by a new kind of link, represented by dotted arrows. This will enable us to combine conventional fault trees and Markov processes in a completely new way. The BDMPs drastically reduce combinatorial problems in operational applications. From a mathematical point of view, a BDMP is a way of defining a global Markov process which is interacting in a given manner. The definition of BDMP is:

- It is basically a Markov process with two “modes”, the components that are required and the components that is in standby. The modes can be different in some cases. Obviously, the system can have only one mode.
- At any time the choice of the mode of one Markov process depends on the value of the Boolean function of the other processes.

A BDMP consists of a: multi-top coherent fault tree, a set of triggers, and a set of triggered Markov processes. A trigger is represented graphically with a dotted line in figure 6.1. The first element of a trigger is called its origin, and the second element is called target. Two triggers must have the same target. This means that it is necessary to create an additional gate G1 in figure 6.1, whose function is only to define the origin of the trigger. The basic events in the figure 6.1 are e1, e2, e3, and e4. There is only one trigger from G1 to G2 [69].

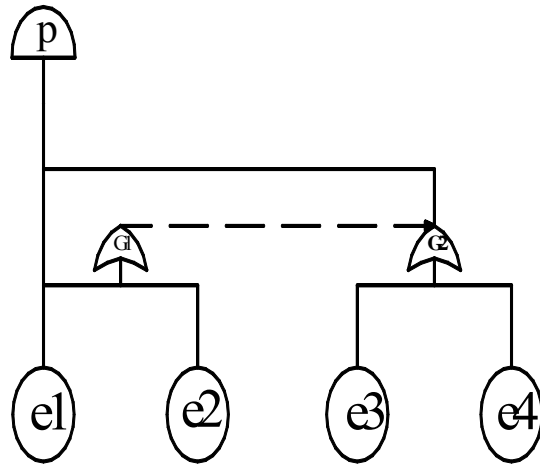

Figure 6.1. BDMP with one Trigger

In figures 6.2, 6.3, and 6.4 the BDMP is presented along with a Markov model.

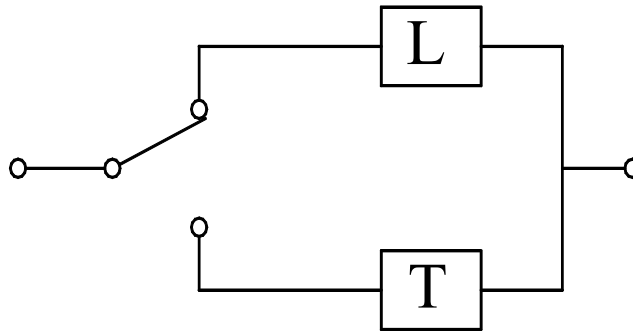

Figure 6.2. Standby System

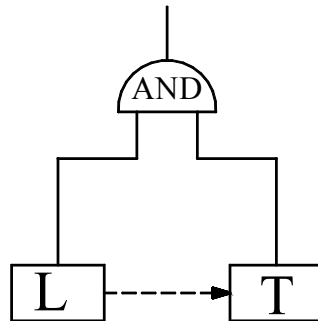

Figure 6.3. BDMP Representation of the System in Figure 6.2

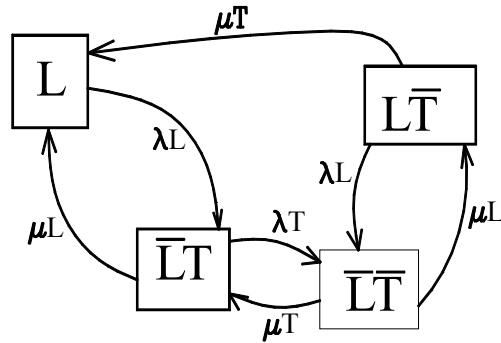

Figure 6.4. Markov Model Representation of the System in Figure 6.2 –State Space Diagram

### 6.1.3 Markov Modeling of Smart Grid Under Variable Weather Condition

The failure rates of the smart grid components located in relatively fixed environments can be considered to be a constant during the useful life period. For transmission lines and other outdoor components, the environment is not a constant and can have a considerable effect upon their failure rates. These two states have a fluctuating environment covering normal and stormy weather with assumed exponential distributions functions. With these assumptions, the Markov approach can be applied to a single unit with a two state failure environment [72, 73, 74].

To use this approach we have to define:

- $\lambda, \mu$  = normal weather failure and repair rates
- $\lambda_s, \mu_s$  = stormy weather failure and repair rates
- $m = \frac{1}{S}$  where S is expected duration of stormy weather
- $n = \frac{1}{N}$  where N is expected duration of normal weather

The state space diagram for the Markov model with one component and variable weather conditions is shown in Figure 6.5

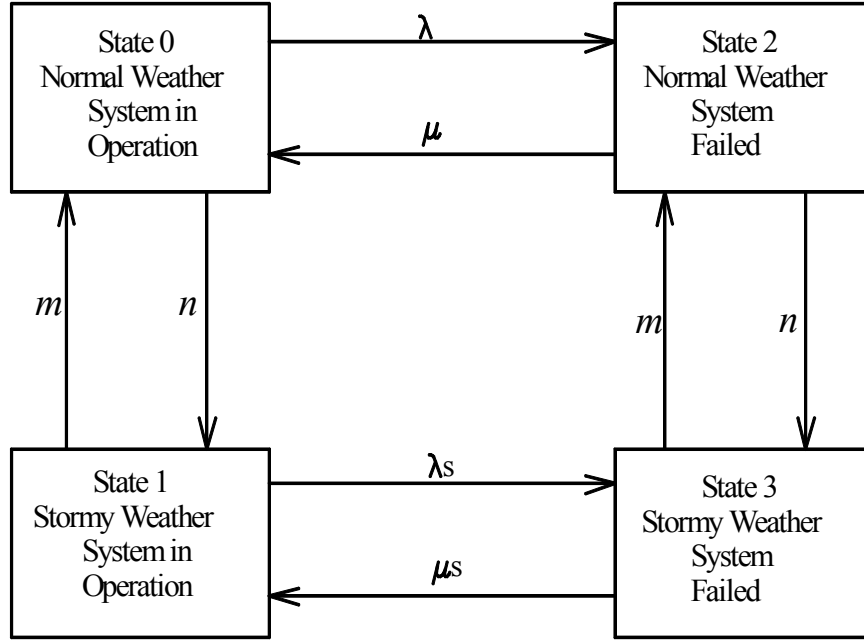

Figure 6.5. Single Unit State Space Diagram

Differential equations for this diagram in matrix forms are:

$$\begin{bmatrix} P_0'(t) \\ P_1'(t) \\ P_2'(t) \\ P_3'(t) \end{bmatrix} = [P_0(t) \ P_1(t) \ P_2(t) \ P_3(t)] \begin{bmatrix} -(\lambda+n) & n & \lambda & 0 \\ m & -(m+\lambda_s) & 0 & \lambda_s \\ \mu & 0 & -(\mu+m) & n \\ 0 & \mu_s & m & -(\mu_s+m) \end{bmatrix}$$

(6.25)

The steady state probabilities can be found from the matrix defined in (6.25).

$$\begin{aligned} -(\lambda+n)P_0 + mP_1 + \mu P_2 &= 0 \\ nP_0 - (m+\lambda_s)P_1 + \mu_s P_3 &= 0 \\ \lambda P_0 - (\mu+n)P_2 + mP_3 &= 0 \\ P_0 + P_1 + P_2 + P_3 &= 1 \end{aligned} \quad (6.26)$$

For this system:

$P(\text{System Operating}) = P_0 + P_1$ , availability

$P(\text{System Failed}) = P_2 + P_3$ , unavailability

Implementation of smart grid technologies into the power system creates a completely new structure, the smart grid. Evaluations and analysis of smart grid reliability with dynamic reconfiguration and variable weather conditions with existing analytical tools and methods is presently not possible, so the new modeling tools and techniques must be developed. The goal can be achieved by formulating a new method which combines techniques used for analysis of dynamic systems and techniques used for analysis of the power system with variable weather conditions. We developed a new method called the Variable Weather Boolean Logic Driven Markov Process or Variable Weather BDMP. This innovation combines two modeling techniques: Markov modeling and modeling of variable weather conditions. The BDMP modeling approach offers advantages over conventional models because it allows complex dynamic models to be defined under variable weather conditions.



## 7. SMART GRID MODELING AND ANALYSIS

The smart grid can offer substantial benefits through the integration of different technologies such as, renewable energy, storage batteries, power and control electronics.

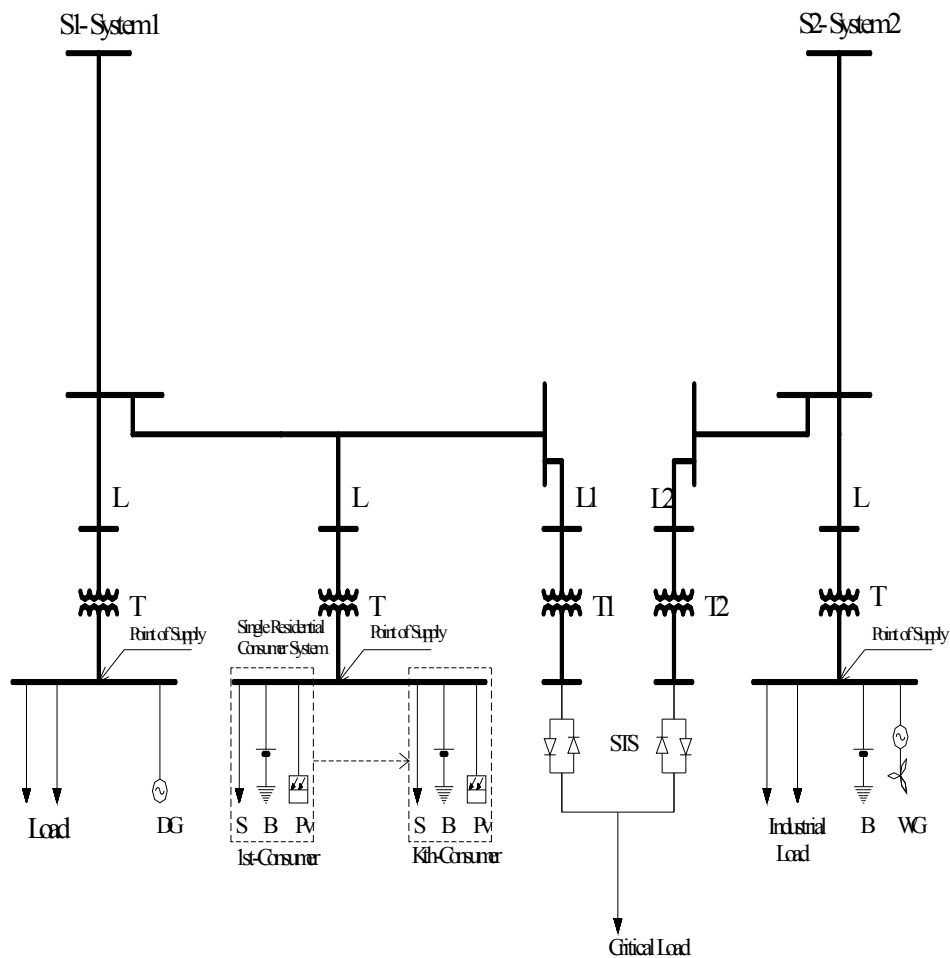

Figure 7.1. Smart Grid Single Line Diagram

A smart grid brings better operation of a power system in terms of power losses and reliability. In this section, we will analyze the smart grid shown in Figure 7.1, under

variable weather conditions. We will use methods described in Chapter 6 (Boolean Logic Driven Markov Process (BDMP) under variable weather condition), in our case of normal weather and stormy weather. In the main smart grid system, we have several subsystems: System with Distribution Generator, System with Battery Storage and Photovoltaic, System with Wind Generator and Battery Storage, and Static Transfer Switch.

The reliability of all subsystems will be analyzed separately. The systems will be analyzed in many ways, such as: with no influence of weather, no smart grid elements, with smart grid elements and normal weather, and with the smart grid elements and stormy weather. As for the reliability indices, we will consider availability and unavailability of the power supply to the particular consumer, industrial, commercial or residential.

### **7.1 System with Distributed Generator (DG)**

Distributed Generators (DG) can have an influence on the systems reliability. There are many technologies used for DG, including renewable energy (wind powered induction generators, photovoltaic, small hydro), gas turbine driven synchronous generators, fuel cells and others. The system we considered consists of:

- L – Overhead transmissions line
- T- Power Transformer
- DG- Distribution Generator
- Load

Here we are focusing on the most common applications for example, backup generation, used in hospitals, shopping centers, etc. The basic connection is shown in

Figure 7.2. The Distribution Generator remains offline during normal operation, and is started if the utility supply is interrupted in order to feed the critical load.

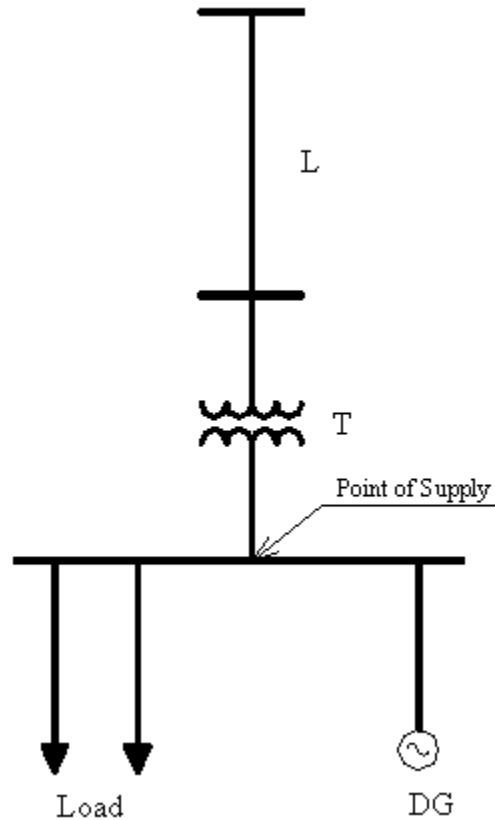

Figure 7.2. System with Distribution Generator (DG) Single Line Diagram

### 7.1.1. System with no DG and no Influence of Weather

Parameter values for a Markov Model of a system with no DG and no weather conditions:

- $\lambda_L = 0.5 / yr (0.0000517 / hr)$
- $\mu_L = 0.25 / yr (MTTR = 4hr)$
- $\lambda_T = 0.34 / yr (0.00000388 / hr)$
- $\mu_T = 0.0167 / yr (MTTR = 60hr)$

The state space diagram is shown in Figure 7.3

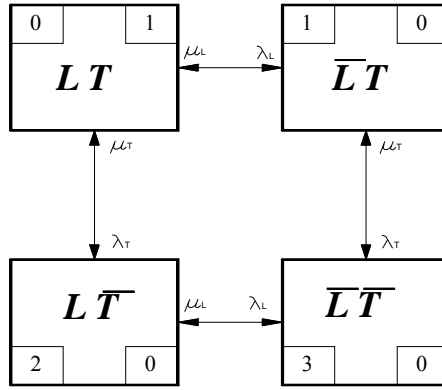

Figure 7.3. State Space Diagram for System with no DG no Weather Conditions

Differential equations for this diagram in matrix form are:

$$\begin{bmatrix} P_0'(t) \\ P_1'(t) \\ P_2'(t) \\ P_3'(t) \end{bmatrix} = \begin{bmatrix} -(\lambda_L + \lambda_T) & \mu_L & \mu_T & 0 \\ \lambda_L & -(\lambda_T + \mu_L) & 0 & \mu_T \\ \lambda_T & 0 & -(\mu_T + \lambda_L) & \mu_L \\ 0 & \lambda_T & \lambda_L & -(\mu_L + \mu_T) \end{bmatrix} \begin{bmatrix} P_0(t) \\ P_1(t) \\ P_2(t) \\ P_3(t) \end{bmatrix} \quad (7.1)$$

The steady state probabilities can be found by solving equation (7.2):

$$\begin{bmatrix} 1 \\ 0 \\ 0 \\ 0 \end{bmatrix} = \begin{bmatrix} 1 & 1 & 1 & 1 \\ 0.0000571 & -0.0250038 & 0 & 0.016666 \\ 3.8812E-5 & 0 & -0.51666 & 0.25 \\ 0 & 3.8812E-5 & 0.0000571 & -0.26666 \end{bmatrix} \begin{bmatrix} P_0(t) \\ P_1(t) \\ P_2(t) \\ P_3(t) \end{bmatrix} \quad (7.2)$$

$$\begin{bmatrix} P_0 \\ P_1 \\ P_2 \\ P_3 \end{bmatrix} = \begin{bmatrix} 0.9996953 \\ 0.0002282 \\ 7.51226E-5 \\ 4.9314E-0.8 \end{bmatrix} \quad (7.3)$$

For this system:

$$P(\text{Availability of Power Supply}) = P_0 = 0.9999684$$

$$P(\text{Unavailability of Power Supply}) = P_1 + P_2 + P_3 = 0.000316$$

### 7.1.2 System with no DG and with Normal Weather Conditions

Parameter values for Markov Models of system with DG and normal weather conditions:

- $\lambda_L = 0.75 / yr(8.561E - 05 / hr)$
- $\mu_L = 0.25 / yr(MTTR = 4hr)$
- $\lambda_T = 0.34 / yr(0.00000388 / hr)$
- $\mu_T = 0.0167 / yr(MTTR = 60hr)$

The system has the same structure as the system with no weather conditions. The Markov state space diagram of the system is the same, and so is the transition matrix. The solution for the steady state probabilities are:

$$\begin{bmatrix} P_0 \\ P_1 \\ P_2 \\ P_3 \end{bmatrix} = \begin{bmatrix} 0.999652147 \\ 0.000335545 \\ 0.000142886 \\ 9.297E - 0.8 \end{bmatrix} \quad (7.4)$$

For this system:

$$P(\text{Availability of Power Supply}) = P_0 = 0.99952147$$

$$P(\text{Unavailability of Power Supply}) = P_1 + P_2 + P_3 = 0.000478524$$

### 7.1.3 System with DG and No Influence of Weather

Parameter values for Markov Model of a system with DG and no weather conditions:

- $\lambda_L = 0.5 / yr(0.0000517 / hr)$
- $\mu_L = 0.25 / yr(MTTR = 4hr)$
- $\lambda_T = 0.34 / yr(0.00000388 / hr)$

- $\mu_T = 0.0167 / yr (MTTR = 60hr)$
- $\lambda_G = 0.2 / yr (0.00000228 / hr)$
- $\mu_G = 0.125 / yr (MTTR = 8hr)$

Using BDMP, described in Chapter 6, the state space diagram, Figure 7.4 is:

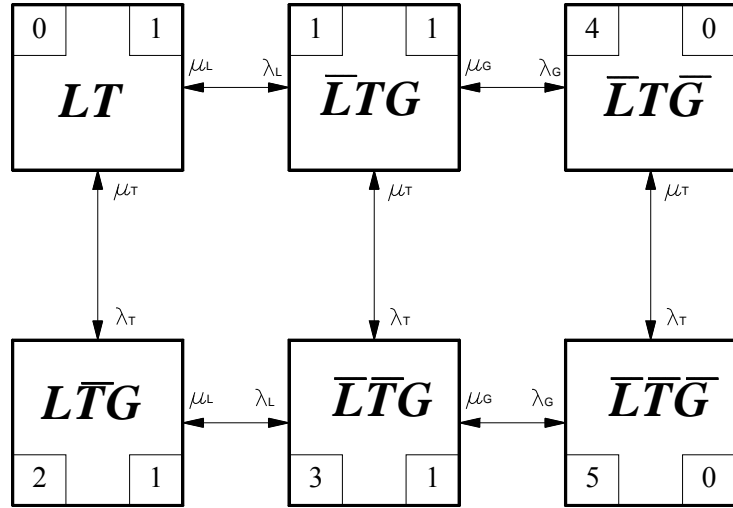

Figure 7.4. State Space Diagram for System with DG No Weather Conditions

Differential equations for this diagram in matrix forms are:

$$\begin{bmatrix} \dot{P}_0(t) \\ \dot{P}_1(t) \\ \dot{P}_2(t) \\ \dot{P}_3(t) \\ \dot{P}_4(t) \\ \dot{P}_5(t) \end{bmatrix} = \begin{bmatrix} -(\lambda_L + \lambda_T) & \mu_L & \mu_T & 0 & 0 & 0 \\ \lambda_L & -(\lambda_T + \mu_L + \lambda_G) & 0 & \mu_T & 0 & 0 \\ \lambda_T & 0 & -(\mu_T + \lambda_L) & \mu_L & 0 & 0 \\ 0 & \lambda_T & \lambda_L & -(\mu_L + \mu_T + \lambda_G) & 0 & \mu_G \\ 0 & \lambda_G & 0 & 0 & -(\mu_G + \lambda_T) & \mu_T \\ 0 & 0 & 0 & \lambda_G & \lambda_T & -(\mu_G + \mu_T) \end{bmatrix} \begin{bmatrix} P_0(t) \\ P_1(t) \\ P_2(t) \\ P_3(t) \\ P_4(t) \\ P_5(t) \end{bmatrix} \quad (7.5)$$

The steady state probabilities can be found by solving equation (7.5) :

$$\begin{bmatrix} P_0 \\ P_1 \\ P_2 \\ P_3 \\ P_4 \\ P_5 \end{bmatrix} = \begin{bmatrix} 0.9974487 \\ 0.0002278 \\ 0.0023228 \\ 5.305E-07 \\ 4.55E-08 \\ 9.67E-11 \end{bmatrix} \quad (7.6)$$

For this system:

$$P(\text{Availability of Power Supply}) = P_0 + P_1 + P_2 + P_3 = 0.999999958$$

$$P(\text{Unavailability of Power Supply}) = P_4 + P_5 = 4.165E-08$$

#### 7.1.4 System with DG and Alternative Weather Conditions, Normal and Stormy

##### Weather

Parameter values for a Markov Model of the system with DG alternative weather conditions are:

- Normal Weather Conditions

$$\lambda_L = 0.75 / \text{yr} (8.5616E-05 / \text{hr})$$

$$\mu_L = 0.25 / \text{yr} (MTTR = 4 \text{hr})$$

$$\lambda_T = 0.34 / \text{yr} (3.8812E-05 / \text{hr})$$

$$\mu_T = 0.0167 / \text{yr} (MTTR = 60 \text{hr})$$

$$\lambda_G = 0.2 / \text{yr} (2.28E-05 / \text{hr})$$

$$\mu_G = 0.125 / \text{yr} (MTTR = 8 \text{hr})$$

$$N = 200 \text{hr} \quad \text{Normal Weather Duration}$$

$$n = \frac{1}{N} = 0.005$$

- Stormy Weather Conditions

$$\lambda'_L = 0.95 / yr(0.000108447 / hr)$$

$$\mu'_L = 0.25 / yr(MTTR = 4hr)$$

$$\lambda'_T = 0.55 / yr(6.2785E - 05 / hr)$$

$$\mu'_T = 0.0167 / yr(MTTR = 60hr)$$

$$\lambda'_G = 0.2 / yr(2.28E - 05 / hr)$$

$$\mu'_G = 0.125 / yr(MTTR = 8hr)$$

$$S = 20hr \text{ Stormy Weather Duration}$$

$$m = \frac{1}{S} = 0.05$$

Using the methods described in Chapter 6, the state space diagram, Figure 7.5 is developed.



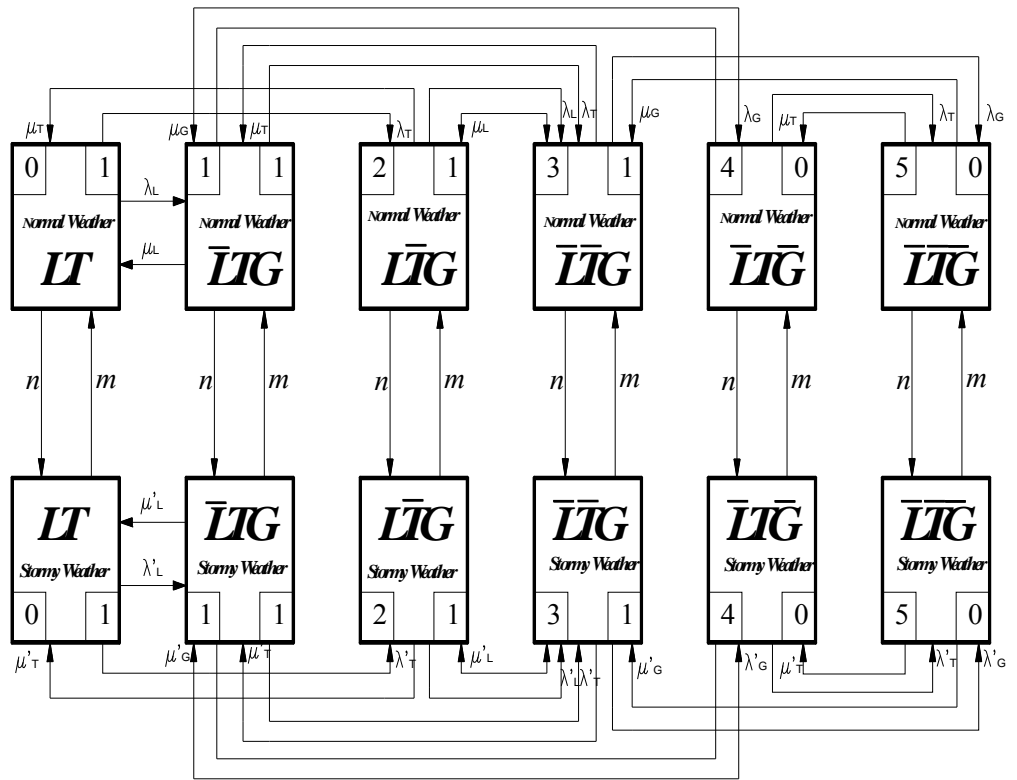

Figure 7.5. State Space Diagram for System with DG and Alternative Weather

Conditions, Normal, and Stormy Weather

Differential equations for this diagram in matrix forms are:

$$[P'(t)] = [P(t)] \begin{bmatrix} D_1 & n[I] \\ - & - \\ m[I] & D_2 \end{bmatrix} \quad (7.7)$$

Where  $D_1$  and  $D_2$  are matrices:

$$D_1 = \begin{bmatrix} -(\lambda_L + \lambda_T + m) & \mu_L & \mu_T & 0 & 0 & 0 \\ \lambda_L & -(\lambda_T + \mu_L + \lambda_G + m) & 0 & \mu_T & 0 & 0 \\ \lambda_T & 0 & -(\mu_T + \lambda_L + m) & \mu_L & 0 & 0 \\ 0 & \lambda_T & \lambda_L & -(\mu_L + \mu_T + \lambda_G + m) & 0 & \mu_G \\ 0 & \lambda_G & 0 & 0 & -(\mu_G + \lambda_T + m) & \mu_T \\ 0 & 0 & 0 & \lambda_G & \lambda_T & -(\mu_G + \mu_T + m) \end{bmatrix} \quad (7.7)$$

$$D_2 = \begin{bmatrix} -(\lambda_L + \lambda_T + m) & \mu_L & \mu_T & 0 & 0 & 0 \\ \lambda_L & -(\lambda_T + \mu_L + \lambda_G + m) & 0 & \mu_T & 0 & 0 \\ \lambda_T & 0 & -(\mu_T + \lambda_L + m) & \mu_L & 0 & 0 \\ 0 & \lambda_T & \lambda_L & -(\mu_L + \mu_T + \lambda_G + m) & 0 & \mu_G \\ 0 & \lambda_G & 0 & 0 & -(\mu_G + \lambda_T + m) & \mu_T \\ 0 & 0 & 0 & \lambda_G & \lambda_T & -(\mu_G + \mu_T + m) \end{bmatrix} \quad (7.8)$$

The steady state probabilities can be found by solving equation (7.7):

$$\begin{bmatrix} P_0 \\ P_1 \\ P_2 \\ P_3 \\ P_4 \\ P_5 \\ P'_0 \\ P'_1 \\ P'_2 \\ P'_3 \\ P'_4 \\ P'_5 \end{bmatrix} = \begin{bmatrix} 0.997877 \\ 0.000335 \\ 0.001788 \\ 6.11E - 07 \\ 5.88E - 08 \\ 1.11E - 10 \\ 0.998698 \\ 0.000361 \\ 0.000941 \\ 3.94E - 07 \\ 1.06E - 07 \\ 1.27E - 10 \end{bmatrix} \quad (7.9)$$

For the system:

- Normal Weather

$$P(\text{Availability of Power Supply}) = P_0 + P_1 + P_2 + P_3 = 0.999999941$$

$$P(\text{Unavailability of Power Supply}) = P_4 + P_5 = 5.894\text{E-}08$$

- Stormy Weather

$$P(\text{Availability of Power Supply}) = P'_0 + P'_1 + P'_2 + P'_3 = 0.999999894$$

$$P(\text{Unavailability of Power Supply}) = P'_4 + P'_5 = 1.06055\text{E-}07$$

## 7.2 System with Photovoltaic (PV) and Energy Storage System

Photovoltaic systems (PV) deliver available renewable resources to a larger energy market. It improves the economics of transmission and the distribution of electrical energy. Today's challenge is that the significant deployment of PV energy requires modernization of the electrical energy distribution grid to a new generation smart grid.

The distribution PV systems operate interactively with available solar resources, varying conditions on the grid, and other local resources, including load control and future generation and storage resources. However, the solar energy has drawbacks since it does not provide a constant supply of energy. There are days where the sun just doesn't come out. When connected to a battery storage system, the energy can be stored and used as needed. The cycle of charging and discharging will repeat itself daily, and the consumer will only have to pay for the initial installation of the system, after that, the energy is literally free.

By storing energy, utilities can eliminate the need for a peaking generator that will only be used when demand is at its highest, and whose capacity will never be realized. In addition, by turning on extra generators, they overshoot the market demand. Consumers who live in remote areas that are not connected to a distribution system can rely on renewable energy to supply them.

The most obvious uses of an Energy Storage System are for better efficiency of the smart grid and for capital gain. Perhaps their biggest advantage is the ability to regulate all the energy that is being produced. By practically eliminating losses through storage and then releasing the required amount during peak times, the system can use all the energy effectively. For this study we are considering individual residential consumers with the following structure, Figure 7.6:

- L – Overhead transmissions line
- T- Power Transformer
- Pv- Photovoltaic
- B- Battery (Energy Storage System)
- S – Residential Consumer

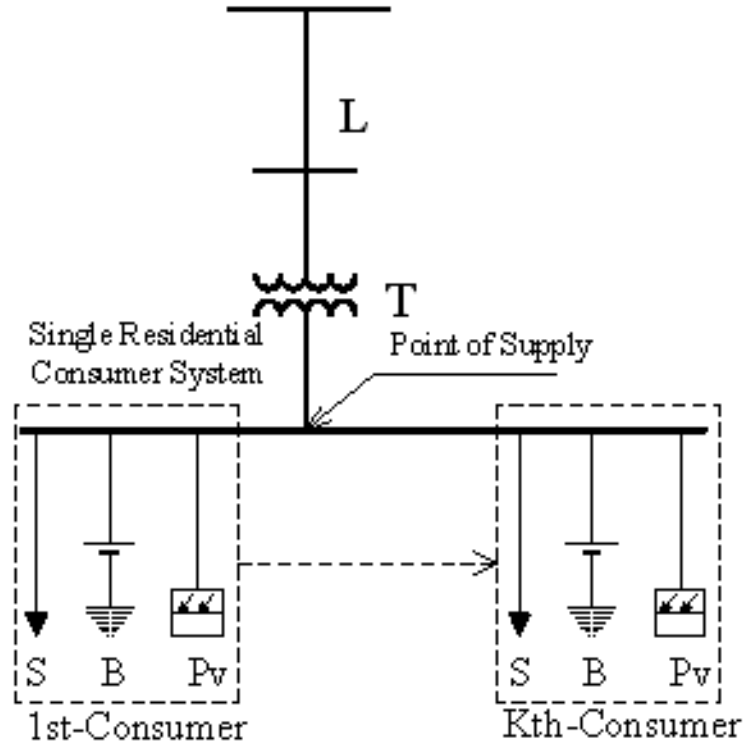

Figure 7.6. System with PV and Energy Storage System (B), Single Line Diagram

### 7.2.1 System with no PV and Battery

The system will consist only of a Line and Transformer. The analysis and the results are the same as for the system with the DG that we analyzed in sections 7.1.1 and 7.12.

### 7.2.2 System with PV and Energy Storage System and no Influence of Weather

Parameter values for a Markov Model for a system with PV and Energy Storage System and no weather conditions are:

- $\lambda_L = 0.5 / yr (0.0000517 / hr)$
- $\mu_L = 0.25 / yr (MTTR = 4hr)$
- $\lambda_T = 0.34 / yr (0.00000388 / hr)$
- $\mu_T = 0.0167 / yr (MTTR = 60hr)$

- $\lambda_{Pv} = 0.02 / yr (0.00000228 / hr)$
- $\mu_{Pv} = 0.25 / yr (MTTR = 4hr)$
- $\lambda_B = 0.1 / yr (0.0000114 / hr)$
- $\mu_B = 0.4 / yr (MTTR = 2.5hr)$

Using BDMP, described in Chapter 6, the state space diagram, figure 7.7, is:

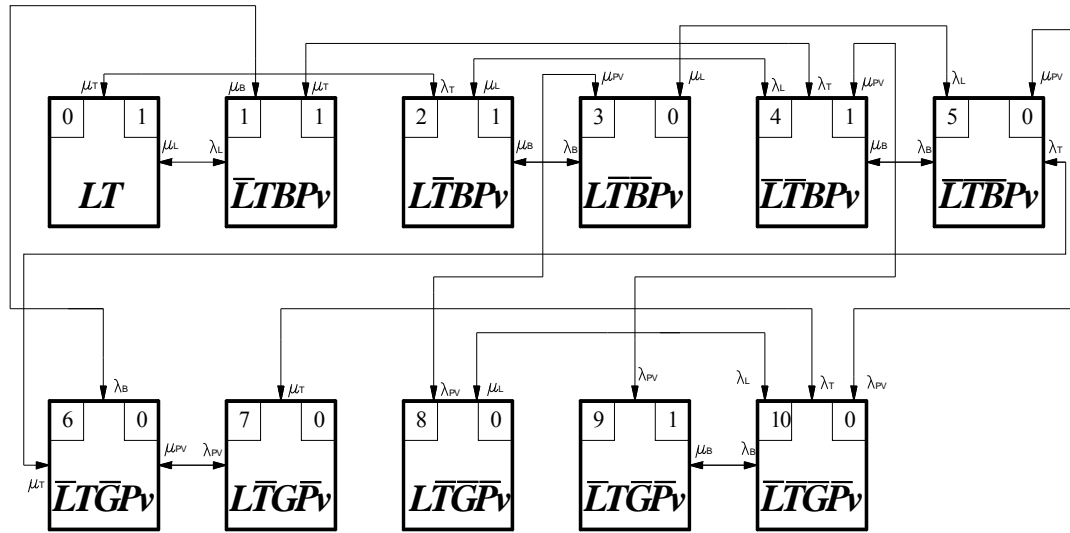

Figure 7.7. State Space Diagram for System with PV and Energy Storage System No Weather Conditions

Differential equations for this diagram in matrix forms are:

$$\begin{aligned}
 \begin{bmatrix} P_0'(t) \\ P_1'(t) \\ P_2'(t) \\ P_3'(t) \\ P_4'(t) \\ P_5'(t) \\ P_6'(t) \\ P_7'(t) \\ P_8'(t) \\ P_9'(t) \\ P_{10}'(t) \\ 0 \\ \mu_B \\ 0 \\ 0 \\ 0 \\ \mu_T \\ -(\lambda_{pV} + \lambda_T + \mu_B) \\ \lambda_{pV} \\ 0 \\ 0 \\ 0 \end{bmatrix} &= \begin{bmatrix} -(\lambda_L + \lambda_T) & \mu_L & \mu_T & 0 & 0 & 0 & 0 & 0 & 0 & 0 & 0 & 0 & 0 & 0 & 0 & 0 & 0 & 0 & 0 & 0 & 0 \\ \lambda_L & -(\lambda_T + \mu_L + \lambda_B) & 0 & 0 & 0 & \mu_T & 0 & 0 & 0 & 0 & 0 & 0 & 0 & 0 & 0 & 0 & 0 & 0 & 0 & 0 & 0 \\ \lambda_T & 0 & -(\lambda_B + \mu_T + \lambda_L) & \mu_B & \mu_L & 0 & 0 & 0 & 0 & 0 & 0 & 0 & 0 & 0 & 0 & 0 & 0 & 0 & 0 & 0 & 0 \\ 0 & 0 & \lambda_B & -(\lambda_L + \lambda_{pV} + \mu_B) & 0 & 0 & 0 & 0 & 0 & 0 & 0 & 0 & 0 & 0 & 0 & 0 & 0 & 0 & 0 & 0 & \mu_L \\ 0 & \lambda_T & \lambda_L & 0 & 0 & -(\mu_T + \mu_{pV} + \lambda_B) & \mu_B & 0 & 0 & 0 & 0 & 0 & 0 & 0 & 0 & 0 & 0 & 0 & 0 & 0 & \mu_B \\ 0 & 0 & 0 & 0 & \lambda_L & \lambda_B & -(\lambda_B + \mu_T + \lambda_B + \mu_{pV}) & 0 & 0 & 0 & 0 & 0 & 0 & 0 & 0 & 0 & 0 & 0 & 0 & 0 & 0 \\ 0 & \lambda_B & 0 & 0 & 0 & 0 & 0 & 0 & 0 & 0 & 0 & 0 & 0 & 0 & 0 & 0 & 0 & 0 & 0 & 0 & \lambda_T \\ 0 & 0 \\ 0 & 0 & 0 & 0 & \lambda_{pV} & 0 & 0 & 0 & 0 & 0 & 0 & 0 & 0 & 0 & 0 & 0 & 0 & 0 & 0 & 0 & 0 \\ 0 & 0 & 0 & 0 & 0 & \lambda_{pV} & 0 & 0 & 0 & 0 & 0 & 0 & 0 & 0 & 0 & 0 & 0 & 0 & 0 & 0 & 0 \\ 0 & \lambda_T \end{bmatrix} \begin{bmatrix} P_0(t) \\ P_1(t) \\ P_2(t) \\ P_3(t) \\ P_4(t) \\ P_5(t) \\ P_6(t) \\ P_7(t) \\ P_8(t) \\ P_9(t) \\ P_{10}(t) \\ P_0(t) \\ P_1(t) \\ P_2(t) \\ P_3(t) \\ P_4(t) \\ P_5(t) \\ P_6(t) \\ P_7(t) \\ P_8(t) \\ P_9(t) \\ P_{10}(t) \end{bmatrix} \quad (7.10)
 \end{aligned}$$

The steady state probabilities can be found by solving equation (7.10):

$$\begin{bmatrix} P_0 \\ P_1 \\ P_2 \\ P_3 \\ P_4 \\ P_5 \\ P_6 \\ P_7 \\ P_8 \\ P_9 \\ P_{10} \end{bmatrix} = \begin{bmatrix} 0.997448836 \\ 0.000227728 \\ 0.002322832 \\ 6.63922E-08 \\ 5.30575E07 \\ 1.77231E-10 \\ 6.49848E-09 \\ 5.93737E-14 \\ 6.06725E-13 \\ 4.84608E-12 \\ 5.42064E-16 \end{bmatrix} \quad (7.11)$$

For this system:

$$P (\text{Availability of Power Supply}) = P_0 + P_1 + P_2 + P_4 + P_9 = 0.9999999269$$

$$P (\text{Unavailability of Power Supply}) = P_3 + P_5 + P_6 + P_7 + P_8 + P_{10} = 7.3000685E-08$$

### 7.2.3 System with PV and Energy Storage System, and Alternative Weather Conditions, Normal and Stormy Weather

Parameter values for a Markov Model of a system with PV and Energy Storage System and alternative weather conditions are:

- Normal Weather Conditions

$$\lambda_L = 0.75 / \text{yr} (8.5616E - 05 / \text{hr})$$

$$\mu_L = 0.25 / \text{yr} (MTTR = 4\text{hr})$$

$$\lambda_T = 0.34 / \text{yr} (3.8812E - 05 / \text{hr})$$

$$\mu_T = 0.0167 / \text{yr} (MTTR = 60\text{hr})$$

$$\lambda_{Pv} = 0.08 / \text{yr} (0.00000228 / \text{hr})$$

$$\mu_{Pv} = 0.25 / \text{yr} (MTTR = 4\text{hr})$$

$$\lambda_B = 0.1 / \text{yr} (0.0000114 / \text{hr})$$

$$\mu_B = 0.4 / \text{yr} (MTTR = 2.5\text{hr})$$

$$N = 200\text{hr} \text{ Normal Weather Duration}$$

$$n = \frac{1}{N} = 0.005$$

- Stormy Weather Conditions

$$\lambda'_L = 0.95 / \text{yr} (0.000108447 / \text{hr})$$

$$\mu'_L = 0.1666 / \text{yr} (MTTR = 6\text{hr})$$



$$\lambda'_T = 0.55 / yr(6.2785E - 05 / hr)$$

$$\mu'_T = 0.0167 / yr(MTTR = 60hr)$$

$$\lambda'_{P_v} = 0.1 / yr(0.00001415 / hr)$$

$$\mu'_{P_v} = 0.1666 / yr(MTTR = 6hr)$$

$$\lambda'_B = 0.1 / yr(0.0000114 / hr)$$

$$\mu'_B = 0.25 / yr(MTTR = 4hr)$$

$S = 20hr$  Stormy Weather Duration

$$m = \frac{1}{S} = 0.05$$

Differential equations for this diagram in matrix forms are:

$$[P'(t)] = [P(t)] \begin{bmatrix} D_1 & n[I] \\ - & - \\ m[I] & D_2 \end{bmatrix} \quad (7.12)$$

Using methods described in Chapter 6, the state space diagram, figure 7.8, is:

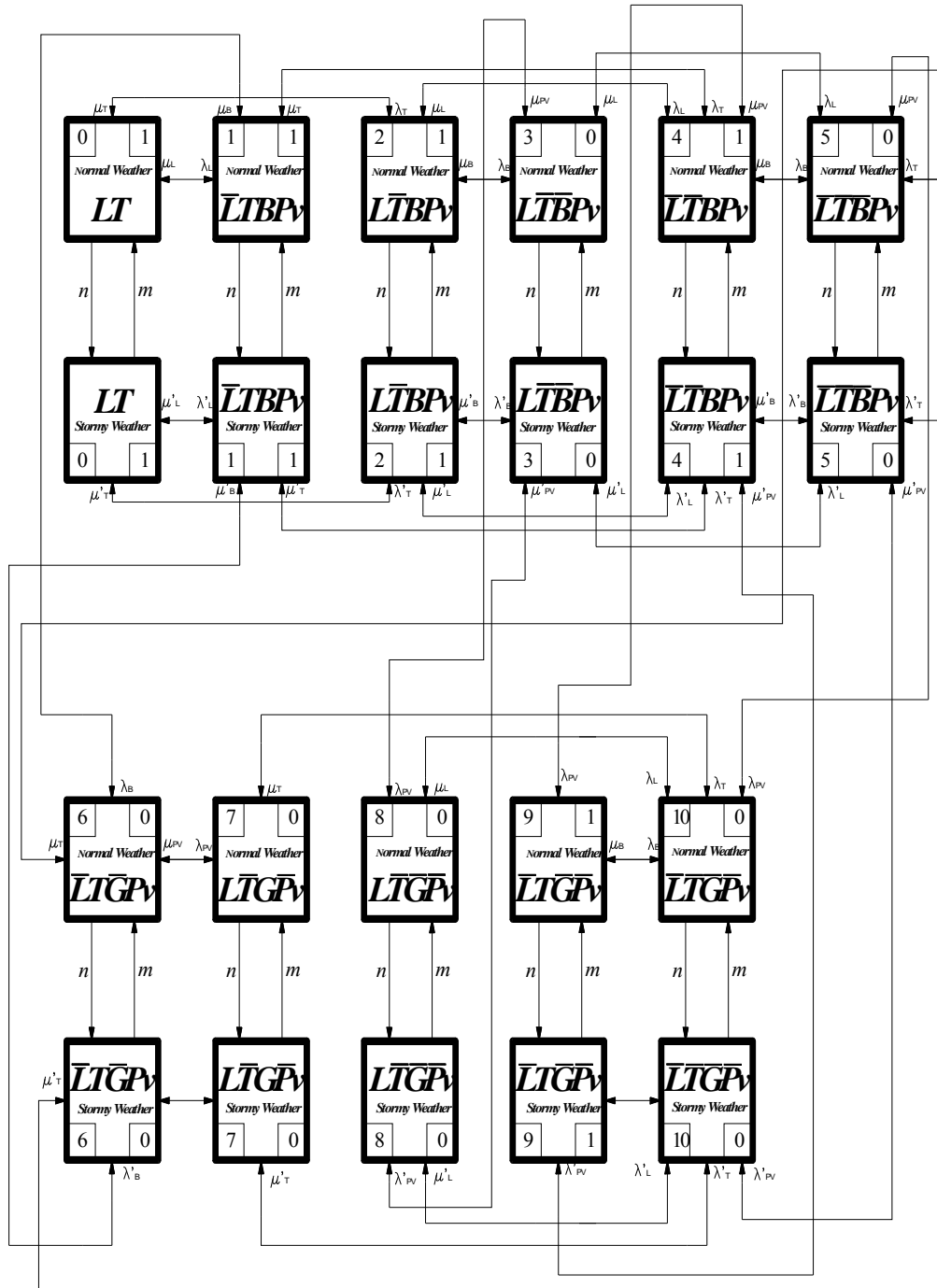

Figure 7.8. State Space Diagram for System with PV and Energy Storage System and Alternative Weather Conditions, Normal, and Stormy Weather

In equation (7.12),  $D_1$  and  $D_2$  are matrices:

$$D_1 = \begin{pmatrix}
 -(\lambda_L + \lambda_T) & \mu_L & \mu_T & 0 & 0 & 0 \\
 \lambda_L & -(\lambda_T + \mu_L + \lambda_B) & 0 & 0 & \mu_T & 0 \\
 \lambda_T & 0 & -(\lambda_B + \mu_T + \lambda_L) & \mu_B & \mu_L & 0 \\
 0 & 0 & \lambda_B & -(\lambda_L + \lambda_{PV} + \mu_B) & 0 & \mu_L \\
 0 & \lambda_T & \lambda_L & 0 & -(\mu_T + \mu_{PV} + \lambda_B) & \mu_B \\
 0 & 0 & 0 & \lambda_L & \lambda_B & -(\lambda_B + \mu_T + \lambda_B + \mu_{PV}) \\
 0 & \lambda_B & 0 & 0 & 0 & \lambda_T \\
 0 & 0 & 0 & 0 & 0 & 0 \\
 0 & 0 & 0 & \lambda_{PV} & 0 & 0 \\
 0 & 0 & 0 & 0 & \lambda_{PV} & 0 \\
 0 & 0 & 0 & 0 & 0 & \lambda_T
 \end{pmatrix}$$

$$D_2 = \begin{pmatrix}
 0 & 0 & 0 & 0 & 0 & 0 \\
 \mu_B & 0 & 0 & 0 & 0 & 0 \\
 0 & 0 & 0 & 0 & 0 & 0 \\
 0 & 0 & \mu_{PV} & 0 & 0 & 0 \\
 0 & 0 & 0 & \mu_{PV} & 0 & 0 \\
 \mu_T & 0 & 0 & 0 & 0 & 0 \\
 -(\lambda_{PV} + \lambda_T + \mu_B) & \mu_{PV} & 0 & 0 & 0 & \mu_{PV} \\
 \lambda_{PV} & -(\lambda_{PV} + \lambda_T) & 0 & 0 & 0 & 0 \\
 0 & 0 & -(\lambda_{PV} + \lambda_L) & 0 & 0 & \mu_T \\
 0 & 0 & 0 & -(\lambda_{PV} + \lambda_B) & 0 & \mu_L \\
 0 & \lambda_T & \lambda_L & \lambda_B & -(\mu_{PV} + \mu_T + \mu_B + \mu_L) & 0
 \end{pmatrix} \quad (7.13)$$

$$D_2 = \begin{bmatrix}
-(\lambda'_L + \lambda'_T) & \mu'_L & \mu'_T & 0 & 0 & 0 \\
\lambda'_L & -(\lambda'_T + \mu'_L + \lambda'_B) & 0 & 0 & \mu'_T & 0 \\
\lambda'_T & 0 & -(\lambda'_B + \mu'_T + \lambda'_L) & \mu'_B & \mu'_L & 0 \\
0 & 0 & \lambda'_B & -(\lambda'_L + \lambda'_{PV} + \mu'_B) & 0 & \mu'_L \\
0 & \lambda'_T & \lambda'_L & 0 & -(\mu'_T + \mu'_{PV} + \lambda'_B) & \mu'_B \\
0 & 0 & 0 & \lambda'_L & \lambda'_B & -(\lambda'_B + \mu'_L + \lambda'_B + \mu'_{PV}) \\
0 & \lambda'_B & 0 & 0 & 0 & \lambda'_T \\
0 & 0 & 0 & 0 & 0 & 0 \\
0 & 0 & 0 & \lambda'_{PV} & 0 & 0 \\
0 & 0 & 0 & 0 & \lambda'_{PV} & 0 \\
0 & 0 & 0 & 0 & 0 & \lambda'_T \\
0 & 0 & 0 & 0 & 0 & 0 \\
\mu'_B & 0 & 0 & 0 & 0 & 0 \\
0 & 0 & 0 & 0 & 0 & 0 \\
0 & 0 & \mu'_{PV} & 0 & 0 & 0 \\
0 & 0 & 0 & \mu'_{PV} & 0 & 0 \\
\mu'_T & 0 & 0 & 0 & 0 & 0 \\
-(\lambda'_{PV} + \lambda'_T + \mu'_B) & \mu'_{PV} & 0 & 0 & 0 & \mu'_{PV} \\
\lambda'_{PV} & -(\lambda'_{PV} + \lambda'_T) & 0 & 0 & 0 & 0 \\
0 & 0 & -(\lambda'_{PV} + \lambda'_L) & 0 & 0 & \mu'_T \\
0 & 0 & 0 & -(\lambda'_{PV} + \lambda'_B) & 0 & \mu'_L \\
0 & \lambda'_T & \lambda'_L & \lambda'_B & -(\mu'_{PV} + \mu'_T + \mu'_B + \mu'_L) & 0
\end{bmatrix} \quad (7.14)$$

The steady state probabilities can be found by solving equation (7.12):

Normal Weather

Stormy Weather

$$\begin{bmatrix} P_0 \\ P_1 \\ P_2 \\ P_3 \\ P_4 \\ P_5 \\ P_6 \\ P_7 \\ P_8 \\ P_9 \\ P_{10} \end{bmatrix} = \begin{bmatrix} 0.997335004 \\ 0.000341553 \\ 0.00232257 \\ 6.64353E-08 \\ 7.95793E-07 \\ 2.65821E-10 \\ 9.7466E-09 \\ 3.56202E-13 \\ 2.42928E-12 \\ 2.90739E-11 \\ 3.25232E-15 \end{bmatrix} \quad \begin{bmatrix} P'_0 \\ P'_1 \\ P'_2 \\ P'_3 \\ P'_4 \\ P'_5 \\ P'_6 \\ P'_7 \\ P'_8 \\ P'_9 \\ P'_{10} \end{bmatrix} = \begin{bmatrix} 0.995598961 \\ 0.000647821 \\ 0.003750572 \\ 1.72014E-07 \\ 2.44214E-06 \\ 1.24487E-09 \\ 2.95751E-08 \\ 2.01785E-12 \\ 1.18033E-11 \\ 1.67302E-10 \\ 2.92133E-14 \end{bmatrix} \quad (7.15)$$

For the system:

- Normal Weather

$$P(\text{Availability of Power Supply}) = P_0 + P_1 + P_2 + P_4 + P_9 = 0.999999924$$

$$P(\text{Unavailability of Power Supply}) = P_3 + P_5 + P_6 + P_7 + P_8 + P_{10} = 7.645E-08$$

- Stormy Weather

$$P(\text{Availability of Power Supply}) = P'_0 + P'_1 + P'_2 + P'_4 + P'_9 = 0.999999792$$

$$P(\text{Unavailability of Power Supply}) = P'_3 + P'_5 + P'_6 + P'_7 + P'_8 + P'_{10} = 2.028E-07$$

### 7.3. System with Wind Generator and Energy Storage System

Wind power is currently supplying a noticeable amount of electricity around the world. In some countries, about 20% of electrical loads are supplied from the wind generations. Wind generated power is an important part of the smart grid. Some question whether wind power, being a variable resource (meaning it generates electricity when the wind is blowing, not on demand) can be relied upon as part of a system that provides reliable electricity to consumers without interruption. Wind generated power today with the smart grid technologies can readily be accommodated into power electric system operations reliably and economically. As the speed of the wind changes, so does the electrical output from a wind turbine. The Energy Storage System, batteries are needed to store power and smooth out fluctuations in the power supply. In the future, through advances in technologies such as batteries and compressed air, energy storage may become cost-effective. The prospect of plug-in hybrid electric vehicles holds great promise because the expense of their batteries would be covered by their fuel cost savings and they could provide many megawatts of storage for the overall electrical power system. When wind isn't blowing, reliable electrical service is maintained by turning up

the output of other power source to the smart grid system. Wind behaves similar to load in that it is "variable," meaning its output rises and falls within hourly and daily time periods; and it is "non-dispatchable," meaning its output can be controlled only to a limited extent.

Wind turbine system reliability is a critical factor in the success of a wind energy project. A wind turbines reliability is dependent largely on the particular machine model, how well it is designed, and the quality of manufacture. Reliability also varies with the operating environment, as it is the machine's reaction to the wind environment that determines the loading imposed on the components. The variety of potential component failures - gearbox bearings, generator bearings and windings, power electronics, gearbox torque arms, pitch drive electronics – indicate that the operating conditions and load conditions for a large wind turbine and not completely understood.

For this study, we are considering individual industrial consumers supplied by Wind Generations and Energy Storage System with the following structure, figure 7.9:

- L – Overhead transmissions line
- T- Power Transformer
- Wg- Wind Generator
- B- Battery (Energy Storage System)
- Industrial Consumer

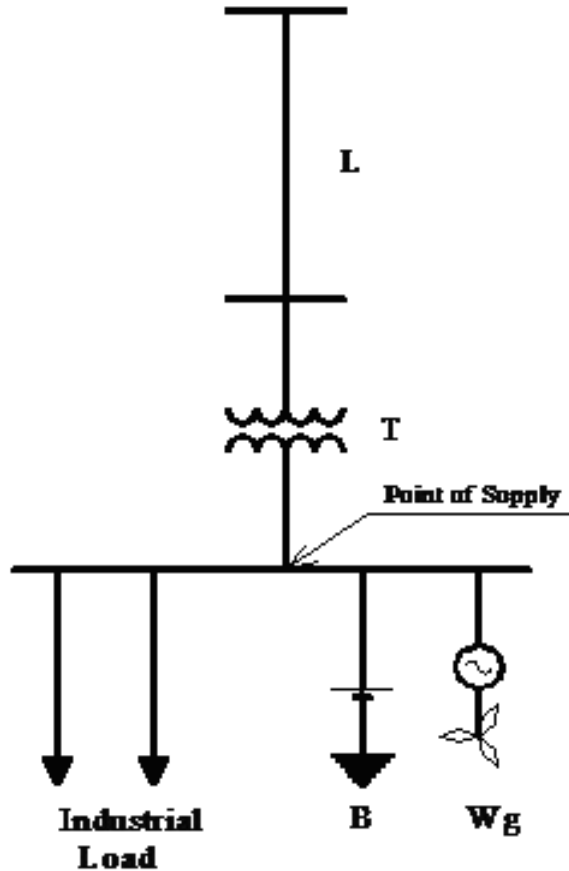

Figure 7.9. System with Wind Generator (Wg) and Energy Storage System (B), Single Line Diagram

### 7.3.1 System with no Wind Generator and Energy Storage System (Battery)

The system will consist only of a Line and Transformer. The analysis and the results will be the same as for the system with the DG, we analyzed in 7.1.1 and 7.12.

### 7.3.2 System with Wind Generator and no Influence of Weather

Parameter values for Markov Model for system with Wind Generator and Energy Storage System and no weather conditions:

- $\lambda_L = 0.5 / yr (0.0000517 / hr)$
- $\mu_L = 0.25 / yr (MTTR = 4hr)$

- $\lambda_T = 0.34 / yr (0.00000388 / hr)$
- $\mu_T = 0.0167 / yr (MTTR = 60hr)$
- $\lambda_G = 0.05 / yr (0.000005707 / hr)$
- $\mu_{Pv} = 0.2 / yr (MTTR = 5hr)$
- $\lambda_B = 0.1 / yr (0.0000114 / hr)$
- $\mu_B = 0.4 / yr (MTTR = 2.5hr)$

Using BDMP, described in Chapter 6, the state space diagram, figure 7.10, is:

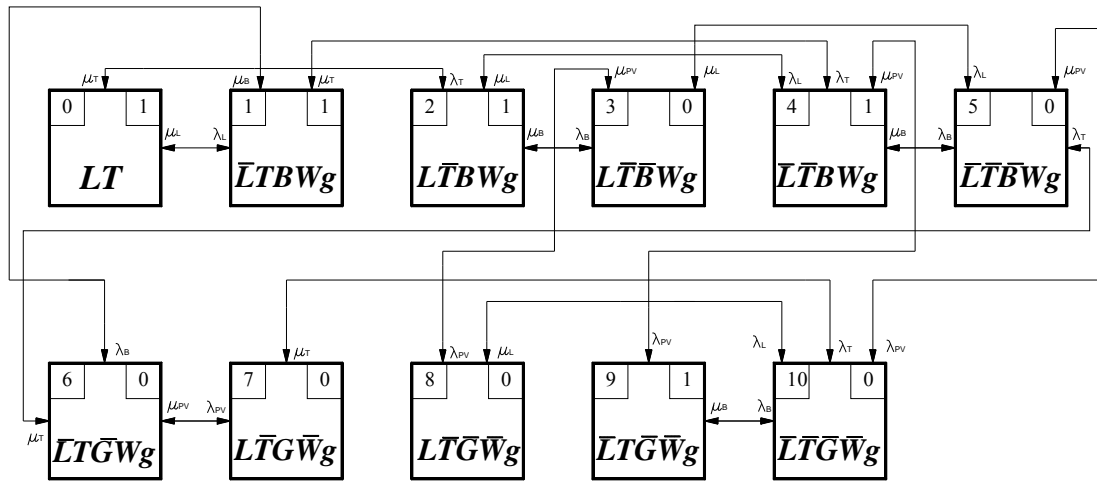

Figure 7.10. State Space Diagram for System with Wg and Energy Storage System no Weather Conditions

Differential equations for this diagram in matrix forms are:



$$\begin{bmatrix} P_0'(t) \\ P_1'(t) \\ P_2'(t) \\ P_3'(t) \\ P_4'(t) \\ P_5'(t) \\ P_6'(t) \\ P_7'(t) \\ P_8'(t) \\ P_9'(t) \\ P_{10}'(t) \end{bmatrix} = \begin{bmatrix} -(\lambda_L + \lambda_T) & \mu_L & \mu_T & 0 & 0 & 0 \\ \lambda_L & -(\lambda_T + \mu_L + \lambda_B) & 0 & 0 & \mu_T & 0 \\ \lambda_T & 0 & -(\lambda_B + \mu_T + \lambda_L) & \mu_B & \mu_L & 0 \\ 0 & 0 & \lambda_B & -(\lambda_L + \lambda_{wg} + \mu_B) & 0 & \mu_L \\ 0 & \lambda_T & \lambda_L & 0 & -(\mu_T + \mu_{wg} + \lambda_B) & \mu_B \\ 0 & 0 & 0 & \lambda_L & \lambda_B & -(\lambda_B + \mu_T + \lambda_B + \mu_{wg}) \\ 0 & \lambda_B & 0 & 0 & 0 & \lambda_T \\ 0 & 0 & 0 & 0 & 0 & 0 \\ 0 & 0 & 0 & \lambda_{wg} & 0 & 0 \\ 0 & 0 & 0 & 0 & \lambda_{wg} & 0 \\ 0 & 0 & 0 & 0 & 0 & \lambda_T \end{bmatrix} \begin{bmatrix} P_0(t) \\ P_1(t) \\ P_2(t) \\ P_3(t) \\ P_4(t) \\ P_5(t) \\ P_6(t) \\ P_7(t) \\ P_8(t) \\ P_9(t) \\ P_{10}(t) \end{bmatrix} + \begin{bmatrix} 0 & 0 & 0 & 0 & 0 & 0 \\ \mu_B & 0 & 0 & 0 & 0 & 0 \\ 0 & 0 & 0 & 0 & 0 & 0 \\ 0 & 0 & \mu_{wg} & 0 & 0 & 0 \\ 0 & 0 & 0 & \mu_{wg} & 0 & 0 \\ \mu_T & 0 & 0 & 0 & 0 & 0 \\ -(\lambda_{wg} + \lambda_T + \mu_B) & \mu_{wg} & 0 & 0 & \mu_{wg} & 0 \\ \lambda_{wg} & -(\lambda_{wg} + \lambda_T) & 0 & 0 & 0 & 0 \\ 0 & 0 & -(\lambda_{wg} + \lambda_L) & 0 & \mu_T & 0 \\ 0 & 0 & 0 & -(\lambda_{wg} + \lambda_B) & \mu_L & 0 \\ 0 & \lambda_T & \lambda_L & \lambda_B & -(\mu_{wg} + \mu_T + \mu_B + \mu_L) & 0 \end{bmatrix} \begin{bmatrix} P_0(t) \\ P_1(t) \\ P_2(t) \\ P_3(t) \\ P_4(t) \\ P_5(t) \\ P_6(t) \\ P_7(t) \\ P_8(t) \\ P_9(t) \\ P_{10}(t) \end{bmatrix} \quad (7.16)$$

The steady state probabilities can be found by solving equation (7.16):

$$\begin{bmatrix} P_0 \\ P_1 \\ P_2 \\ P_3 \\ P_4 \\ P_5 \\ P_6 \\ P_7 \\ P_8 \\ P_9 \\ P_{10} \end{bmatrix} = \begin{bmatrix} 0.997446872 \\ 0.000227736 \\ 6.64458E-08 \\ 6.64458E-08 \\ 6.53508E-07 \\ 1.79345E-10 \\ 6.4987E-09 \\ 1.85559E-13 \\ 1.89769E-12 \\ 1.86524E-11 \\ 1.506012-15 \end{bmatrix} \quad (7.17)$$

For this system:

$$P(\text{Availability of Power Supply}) = P_0 + P_1 + P_2 + P_4 + P_9 =$$

$$P(\text{Unavailability of Power Supply}) = P_3 + P_5 + P_6 + P_7 + P_8 + P_{10} = 7.31259E-08$$

### 7.3.3 System with Wind Generator and Energy Storage System, and Alternative Weather Conditions Normal and Stormy Weather

Parameter values for Markov Model of system with Wind Generator and Energy Storage System and alternative weather conditions are:

- Normal Weather Conditions

$$\lambda_L = 0.75 / yr (8.5616E - 05 / hr)$$

$$\mu_L = 0.25 / yr (MTTR = 4hr)$$

$$\lambda_T = 0.34 / yr (3.8812E - 05 / hr)$$

$$\mu_T = 0.0167 / yr (MTTR = 60hr)$$

$$\lambda_{wg} = 0.09 / yr (0.00001027 / hr)$$

$$\mu_{wg} = 0.142 / yr (MTTR = 7hr)$$

$$\lambda_B = 0.1 / yr (0.0000114 / hr)$$

$$\mu_B = 0.4 / yr (MTTR = 2.5hr)$$

$$N = 200hr \text{ Normal Weather Duration}$$

$$n = \frac{1}{N} = 0.005$$

- Stormy Weather Conditions

$$\lambda'_L = 0.95 / yr(0.000108447 / hr)$$

$$\mu'_L = 0.25 / yr(MTTR = 4hr)$$

$$\lambda'_T = 0.55 / yr(6.2785E - 05 / hr)$$

$$\mu'_T = 0.0167 / yr(MTTR = 60hr)$$

$$\lambda'_{wg} = 0.2 / yr(0.0000228 / hr)$$

$$\mu'_{wg} = 0.1 / yr(MTTR = 10hr)$$

$$\lambda'_B = 0.1 / yr(0.0000114 / hr)$$

$$\mu'_B = 0.4 / yr(MTTR = 2.5hr)$$

$$S = 20hr \text{ Stormy Weather Duration}$$

$$m = \frac{1}{S} = 0.05$$

Differential equations for this diagram in matrix forms are:

$$[P'(t)] = [P(t)] \begin{bmatrix} D_1 & n[I] \\ - & - \\ m[I] & D_2 \end{bmatrix} \quad (7.18)$$

Using methods described in Chapter 6, the state space diagram, figure 7.11, is given next.

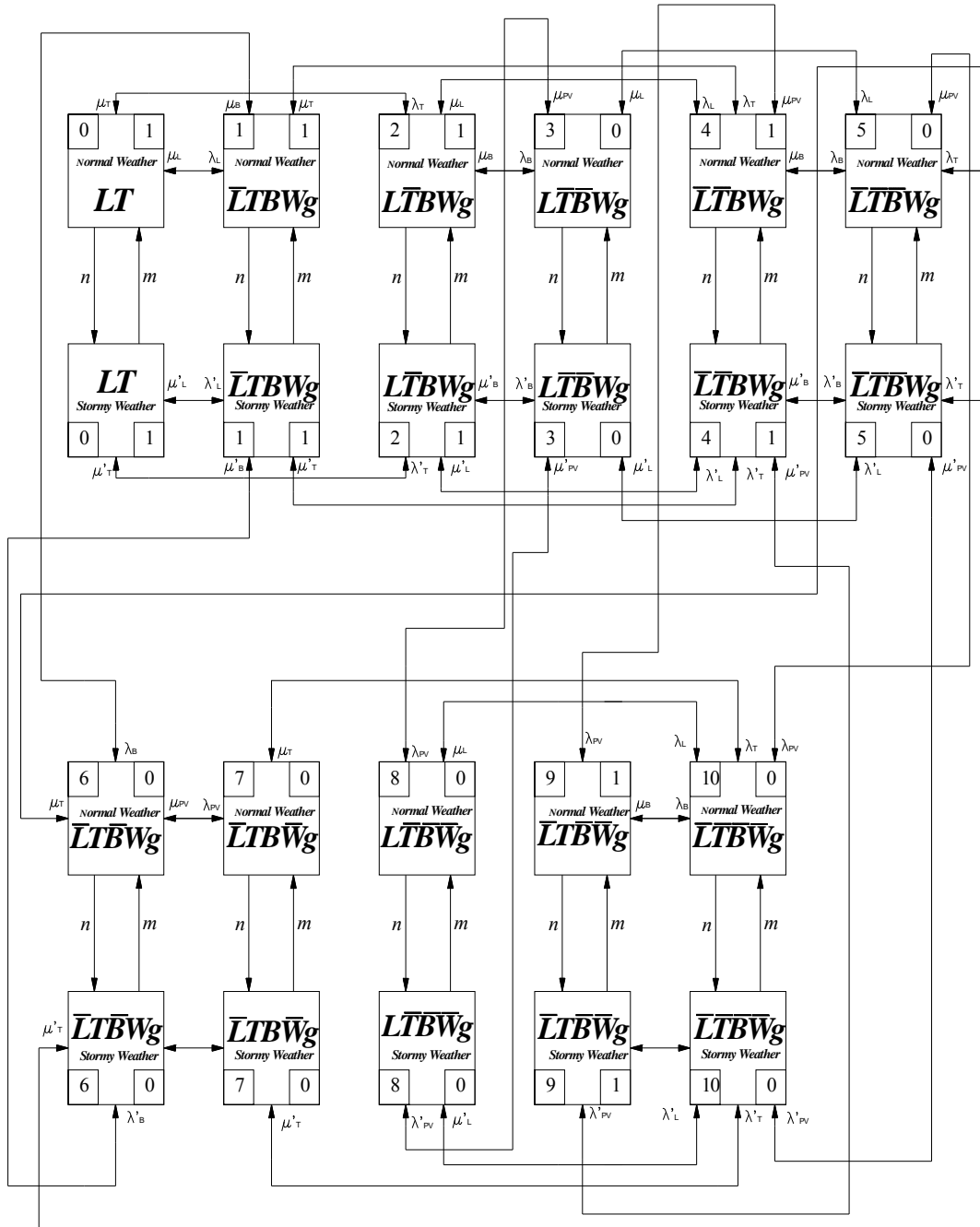

Figure 7.11. State Space Diagram for System with PV and Energy Storage System and Alternative Weather Conditions, Normal, and Stormy Weather



The steady state probabilities can be found by solving equation (7.18):

Normal Weather	Stormy Weather
$\begin{bmatrix} P_0 \\ P_1 \\ P_2 \\ P_3 \\ P_4 \\ P_5 \\ P_6 \\ P_7 \\ P_8 \\ P_9 \\ P_{10} \end{bmatrix} = \begin{bmatrix} 0.997326411 \\ 0.000341586 \\ 0.002330592 \\ 6.667E-08 \\ 1.33462E-06 \\ 2.75101E-10 \\ 9.74754E-09 \\ 7.0146E-13 \\ 4.80131E-12 \\ 9.59902E-11 \\ 5.38644E-15 \end{bmatrix}$	$\begin{bmatrix} P'_0 \\ P'_1 \\ P'_2 \\ P'_3 \\ P'_4 \\ P'_5 \\ P'_6 \\ P'_7 \\ P'_8 \\ P'_9 \\ P'_{10} \end{bmatrix} = \begin{bmatrix} 0.995583479 \\ 0.000647952 \\ 0.003764514 \\ 1.72676E-07 \\ 3.85113E-06 \\ 1.28244E-09 \\ 2.95825E-08 \\ 6.7635E-12 \\ 3.95184E-11 \\ 8.7936E-10 \\ 8.25527E-14 \end{bmatrix} \quad (7.21)$

For the system:

- Normal Weather

$$P(\text{Availability of Power Supply}) = P_0 + P_1 + P_2 + P_4 + P_9 = 0.999999923$$

$$P(\text{Unavailability of Power Supply}) = P_3 + P_6 + P_7 + P_8 + P_{10} = 7.66981E-08$$

- Stormy Weather

$$P(\text{Availability of Power Supply}) = P'_0 + P'_1 + P'_2 + P'_4 + P'_9 = 0.999999796$$

$$P(\text{Unavailability of Power Supply}) = P'_3 + P'_6 + P'_7 + P'_8 + P'_{10} = 2.03587E-07$$

Reliability of the smart grid under normal and stormy weather conditions is analyzed with a new developed method, VW-BDMP (figure 7.1). The analyzed smart grid consists of several subsystems: System with Distribution Generator, System with Battery Storage and Photovoltaic, System with Wind Generator and Battery Storage. The reliability of all subsystems is analyzed separately. The subsystems will be analyzed with no influence of weather, with no smart grid elements, with smart grid elements and normal weather, and with the smart grid elements and stormy weather. For reliability,

indices considered are availability and unavailability of the power supply to the particular consumer--industrial, commercial or residential. The results show improvement of the reliability indices with the smart grid technologies and also show the influence of the weather. The weather expected has a negative influence on the reliability of the smart grid.

## **CHAPTER 8: DISCUSSION, CONCLUSIONS, AND RECOMMENDATIONS FOR FURTHER RESEARCH**

Smart grid engineering is divided into two stages, planning, and design. The planning stage is for identifying system needs and limitations, to propose projects, to resolve issues, and to obtain approvals for projects. The design stage takes a project from concept to the final realization. Smart grid technologies are expected to change fundamental design and operating requirements of the electric power system. The primary engineering tools for smart grid analysis and design are power flow and fault-current studies. Power flow computes steady state voltages and currents of systems ensuring that the system will meet criteria of equipment loading, voltage drops, and system losses. Although power flow modeling can predict electrical properties of the smart grid, reliability modeling predicts the availability and interruptions of such a system. A Smart grid will allow current power electrical systems to incorporate better renewable energy sources such as wind and solar power, back-up distribution generators and energy storage systems.

### **8.1 Discussions and Conclusions**

Reliability of the smart grid is one of the most important areas of reliability theory application. Random failures are certain to occur from time to time, especially when elements of weather or other causes present hazards that the power system was not



designed to withstand. Failures also happen due to poor maintenance, aging, improper processes and multiple other explanations. Reliability methods provide important analytical tools that can be used to evaluate and compare smart grid design and performance since each component has a unique characteristic. Models should be as simple as possible, but they need to represent all features that are critical to systems reliability. Reliability parameters vary from component to component or from situation to situation. Component reliability data are one of the most important parameters of the smart grid reliability assessment. This research used reliable information based on historical utility data, manufacturer test data, documents and references from professional organizations, and other technical conferences and journal proceedings. Electrical equipment reliability data are usually obtained from surveys of individual industrial equipment failure reports. Collection of reliability data is a continuous process since it is constantly updated.

The smart grid reliability indices are used to quantify sustained interruptions. Short duration outages for some customers, such as hospitals and large industrial customers, can result in complex systems shutting down. In many cases, these customers have installed backup generation or other means of addressing short-duration outages. In particular, it is these types of outages that would benefit from the presence of distributed generation and energy storage. Therefore, a reliability index should not only quantify enhanced reliability for sustained interruptions, but also for short-duration outages.

Earlier research work focused on modeling the effects of extreme weather conditions on power distribution systems, and on specific weather parameters causing specific faults in the distribution system. Various methods are there to study extreme

weather conditions such as tornadoes and hurricanes. There are also individual models for interruption causes such as equipment failure. A study of interruptions as a function of common weather has not been done in depth thus far. This study bridges that gap. This type of research was not earlier possible for multiple reasons; the weather recording system has improved recently, the communication network has improved, only lately have smart grid applications and technologies been introduced to the old grid network. These data are required to conduct such research, and was not available earlier.

This study has shown that there is a hidden weather component in most of the causes of interruptions. These interruptions and weather conditions are studied probabilistically and a novel, predictive method has been developed on that basis. A theoretical model based on variable weather conditions is used to predict power distribution interruptions, while immediate weather conditions are used to analyze interruption risk assessment

This study creates a better understanding of the relationship between common weather conditions and the number of interruptions, which in turn will open a completely new spectrum of research on reliability of power distribution systems. This study did not only develop a novel combined theoretical model regarding the effects of common weather (while incorporating existing, relevant ones), but applied them by solving the problem of predicting the daily number of interruptions. Furthermore, risk assessment is a strong tool that can be used by management to achieve maximum efficiency when planning the amount of long and short-term manpower and equipment inventory. This predictor is a patent property of the University of South Florida, Tampa, FL – USA.

Variability of reliability (and reliability indices) from system to system or from year to year within a system (due to circumstances beyond the control of the system operator), are recognized as a problem that interferes with a fair assessment of a system's reliability. The development of a method for normalization of reliability indices for weather is a recognized need and this research suggests a solution.

Dynamic reconfigurations of the smart grid and variable weather conditions create difficulties in reliability modeling and analysis. To overcome these obstacles, a unique method was developed, which combines three modeling techniques: Markov modeling, Boolean Logic Driven Markov Process (BDMP) and Modeling of a variable weather condition. This modeling approach has advantages over conventional models because it allows complex dynamic models to be defined and still remain easily readable.

Markov modeling is a method based on system states and the transition between these states. It can be either discrete or continuous. Discrete Markov modeling is called Discrete Markov Chain, while continuous is called continuous Markov Processes. This research modeled smart grid reliability with a continuous Markov Process. Instead of state probabilities, Markov Processes use state transition rates. This is very suitable in application of smart grid reliability, because failure rates of smart grid components are equivalent to state transition rates. To use Markov modeling, the failures of smart grid components' equipment are assumed to be exponentially distributed, so the failure rates are constant. Also other values such as the switching rate and the repair rate use exponential distributions. Failure rates, the switching rates and the repair rates are reciprocals of the Mean Time to Fail (MTTF), Mean Time to Switch (MTTS) and Mean Time to Repair (MTTR).

The purpose of BDMPs is to provide a new graphic representation of fault trees, augmented only by a new kind of link, which is represented by dotted arrows. This enables combined conventional fault trees and Markov processes in a completely new way. BDMPs dramatically reduce combinatorial problems in operational applications. From a mathematical point of view, a BDMP is made of a multi-top coherent fault tree, a set of triggers and a set of triggered Markov processes.

Systems were analyzed with a distribution generator, a system with a photovoltaic source and energy storage, and a system with a wind generator and energy storage. The systems were all analyzed with no outside influence of weather and any smart grid elements; with smart grid elements and normal weather; and smart grid elements and stormy weather. To view reliability of a smart grid system, availability and unavailability of power supply to the particular consumer, industrial, commercial or residential was studied. The expected results were obtained. The highest unavailability of the system is with no smart grid elements including an influence of weather, following the system with no smart grid elements and no weather. The system, with the smart grid elements and normal weather, has the smallest unavailability, followed by the system with the smart grid and the stormy weather. While availability is in reverse order, the highest availability is the system with smart grid elements and normal weather, followed by the system with the smart grid elements and stormy weather. In addition, there is a noticeable improvement of availability/unavailability of systems with smart grid elements.

The main contributions as discussed earlier can be summarized into a list given below:

- A Method for modeling smart grid dynamic reconfigurations under variable weather condition combining the three modeling techniques (Markov modeling, Boolean Logic Driven Markov Process (BDMP) and the modeling of variable weather conditions).
- Developed a method of predicting power distribution interruptions in a given region based on common weather conditions while assessing the risk of interruptions on immediate weather conditions. Using daily and hourly weather data, the method predicts the number of daily or by-shift interruptions.
- A method was developed for normalizing the reliability indices for common weather conditions. The methods commonly used are based on changes and comparisons of present and past performance. The developed method diminishes the impact of variable weather conditions and makes comparisons that allow for more accurate determination of reliability performance.
- Developed the predictor method that will reduce downtime of power interruptions by proper distribution of the service work force. The model offers an economical tool with negligible maintenance costs to utilities and improves its Systems Average Interruption Frequency Index (SAIFI), while increasing its power transmission.

The goal of this research was to find a new method that can be used for modeling the dynamics of the smart grid with variable weather conditions. It is achieved by a combination of the techniques mentioned earlier. To show and prove the models,

simplified smart grid configurations were used. While the present research goal is achieved with the new proposed method on the small-scale system, recommendations for future research are to develop an algorithm and software for the large-scale system using this developed method.

## **8.2 Recommendations for Future Work**

Smart grid applications and technologies are still being implemented to the transmission and distribution grid systems. Reliability studies of such systems are still in their infancy stage. There are many new things being done on the grid, which is expected to improve its efficiency and reliability. There will be many new things to understand and incorporate in the reliability study. In such situations, a continuous in-depth reliability study is required. It is expected that with the expected improvement in system performance, research in the reliability field has to keep pace to provide novel methods and tools to understand the modern grid.

A smart grid consists of a variety of power components such as transformers, generators, overhead lines, renewable energy resources, energy storage elements and a micro-grid. A smart grid will allow current electricity grids to incorporate better renewable energy sources such as wind and solar power, back-up distribution generators and advanced energy storage systems. Smart grid technologies are expected to change the fundamental design and operating requirements of the electric power system. To understand and analyze smart grid impacts on power system operations and design, several issues have been identified:

- Current reliability analysis and modeling tools must evolve to address the future's more interactive power system and to simplify engineering tools to

more efficiently handle the smart grid technologies' related issues.

- New reliability and other analytical methods/tools are needed to determine effects of penetration of smart grid technologies on operation of the power system, as well as the resultant effects on power system quality, reliability, and availability.
- Modern reliability tools can help in defining strength of grid to absorb more amount of renewable resources that can be installed strategically to serve larger number of customers
- Novel software programs could be developed on the basis of this research to bring in like minded customers to use more amount of renewable energy resources that would help make our world far better place to live.

## REFERENCES

- [1] Warren, C. A. (2002). *Overview of 1366-2001: The full use guide on electric power distribution reliability indices*. Proceedings of the Summer Power Meeting; Chicago: Illinois.
- [2] Bouford, J. D. (2002). *The need to segment abnormal events from the calculation of reliability indices*. Proceedings of the Summer Power Meeting; Chicago: Illinois.
- [3] Christie, R. D. (2003). Statistical classification of major event days in distribution system reliability. *Power Delivery, IEEE Transactions*, 18(4), 1336-1341.
- [4] Williams, C. W. (2002). *Major Reliability Events – Self-Defining?* Proceedings of the Summer Power Meeting; Chicago: Illinois
- [5] Brown, R. E., Gupta, S., Christie, R. D., Venkata, S. S. & Fletcher, R. (1997). Distribution system reliability assessment: Momentary interruptions and storms. *Power Delivery, IEEE Transactions*, 12(4), 1569-1575.
- [6] Coelho, J., Nassar, S. M., Gauche, E., Ricardo, V. W., Queiroz, H. L., de Lima, M., & Lourenco, M. C. (2003). Reliability diagnosis of distribution system under adverse weather conditions. Proceedings of the Power Tech Conference.
- [7] Billinton, R., & Wu, C. (2001). Predictive reliability assessment of distribution systems including extreme adverse weather. Proceedings of the Canadian Conference on Electrical and Computer Engineering.
- [8] Orille, A. L., Bogarra, S., Grau, M. A., & Iglesias, J. (2003). Fuzzy logic techniques to limit lightning surges in a power transformer. Proceedings of the Power Tech Conference.
- [9] Xu, L., Chow, M. Y., & Taylor, L. S. (2003). Analysis of tree-caused faults in power distribution systems. Proceedings of the 35th North American Power Symposium, University of Missouri-Rolla in Rolla, Missouri.
- [10] Higashiyama, Y., Sugimoto, T., Otsubo, S., Sato, F., & Honma, H. (1999). Heavy salt deposition onto a distribution line by a seasonal wind in winter. Power Engineering Society Summer Meeting.
- [11] Yasser M., Ebab. A., & EI-Saademy, F. (2009). Reliability evaluation for distribution system with renewable distribution generating during islanded mode of operation. *IEEE Transactions on Power Systems*, 24(2), 572-581.



- [12] Valle, F., Lobry, J., & Deblecker, O. (2008). System Reliability Assessment Method for Wind Power Generation”, IEEE Transactions on Power Systems, Vol. 23. No.3, August 2008.
- [13] Welte, T. W. (2009). Using state diagrams for modeling maintenance of deteriorating systems. *IEEE Transactions on Power Systems*, 24(1).
- [14] US Electric Power Industry Overview 2007, US Energy Information Administration
- [15] LaCommare, K. H., & Eto. J. H. (2004). *Understanding the Cost of Power Interruptions to U.S. Electricity Customers*. LBNL-55718. Berkeley: Lawrence Berkeley National Laboratory.
- [16] Exploring the imperative of revitalizing America’s electric infrastructure the SMART GRID: An introduction. 2008
- [17] IEEE - Institute of Electrical and Electronics Engineers, Working Group on Distribution Reliability, (2006). *IEEE Benchmarking 2005 Results*. Power Engineering Society, Institute of Electrical and Electronics Engineers, Piscataway: New Jersey. Retrieved from <http://grouper.ieee.org/groups/td/dist/sd/doc/2006-07-BenchmarkingUpdate.pdf>
- [18] Gungor, V. C., Lu, B., Hancke, G. P. (2010). Opportunities and challenges of wireless sensor networks in smart grid - A case study of link quality assessments in power distribution systems. *IEEE Transaction on Industrial Electronics*, 99.
- [19] Saif, U., Gordon, D., & Greaves, D. J. (2001). *Internet Access to Home Area Network*. IEEE Transaction.
- [20] Langer, K. D., Grubor, J., Bouchet, O., El Tabach, M., Walewski, J. W., Randel, S. et al.(2008). Optical wireless communications for broadband access in home area networks. *IEEE Conference on Transparent Optical Networks*, 4, 149 – 154.
- [21] Chuang, A., & Gellings, C. (2009). *Demand-side integration for customer choice through variable service subscription*. Proceedings of the Power & Energy Society General Meeting.
- [22] Chuang, A., & McGranaghan, M. (2008). *Functions of a local controller to coordinate distributed resources in a smart grid*. Proceedings of the Power and Energy Society General Meeting - Conversion and Delivery of Electrical Energy in the 21st Century, IEEE.
- [23] Pruggler, W., Kupzog, F., Bletterie, B., & Helfried, B. (2008). *Active grid integration of distributed generation utilizing existing infrastructure more efficiently - an Austrian case study*. Proceedings of the 5th International Conference on European.

- [24] Lopes, J. A. P., Soares, F. J., & Almeida, P. M. R. (2009). *Identifying management procedures to deal with connection of Electric Vehicles in the grid*. Proceedings of the PowerTech IEEE Bucharest.
- [25] Zhenhua, J., Li, F., Qiao, W. Sun, H., Wan, H., Wang, J. et al. (2009). *A vision of smart transmission grids*. Proceedings of the Power & Energy Society General Meeting.
- [26] Bannister, S., & Beckett, P. (2009). *Enhancing powerline communications in the "Smart Grid" using OFDMA*". Proceedings of the Power Engineering Conference.
- [27] Abdul, A., & Lupas, P. (2009). *Convergence of frequency, time, and data over ethernet networks*. Precision Clock Synchronization for Measurement, Control and Communication, 2009. ISPCS. doi: 10.1109/ISPCS.2009.5340213
- [28] Cai, Y., & Chow, M. (2009). *Exploratory analysis of massive data for distribution fault diagnosis in smart grids*. Proceedings of the Power & Energy Society General Meeting. doi: 10.1109/PES.2009.5275689
- [29] Cleveland, F. M. (2008). *Cyber security issues for Advanced Metering Infrastructure (AMI)*. Power and Energy Society General Meeting - Conversion and Delivery of Electrical Energy in the 21st Century. doi: 10.1109/PES.2008.4596535
- [30] Mal, S. T. (2009). *A synergistic approach to implement demand response, asset management and service reliability using smart metering, AMI and MDM systems*. Power & Energy Society General Meeting. doi: 10.1109/PES.2009.5275280
- [31] DeBlasio, R., & Tom, C. (2008). *Standards for the smart grid*. Proceedings of the Energy 2030 Conference. doi: 10.1109/ENERGY.2008.4780988
- [32] Ma, Y., Long, Z., Tse, N., Osman, A., & Lai, L. L. (2009). *An initial study on computational intelligence for smart grid*. Proceedings of the Eighth International Conference on Machine Learning and Cybernetics, 6, 3425 – 3429.
- [33] Momoh, J. A. (2009). *Smart grid design for efficient and flexible power networks operation and control*. Power Systems Conference and Exposition. doi: 10.1109/PSCE.2009.4840074
- [34] Berende, M. J. C., Slootweg, J. G., Kuiper, J., Peters, J. C. F. M. (2008). *Asset management arguments for smart grids*. SmartGrids for Distribution, 2008. IET-CIRED. CIRED Seminar.
- [35] Prodanovic, M. (n. d.). High-quality power generation through distributed control of a Power Park Microgrid.

- [36] Slootweg, H. (2009). Smart Grids - the future or fantasy? Smart Metering - Making It Happen. IET.
- [37] Amin, M. (2008). Challenges in reliability, security, efficiency, and resilience of energy infrastructure: Toward smart self-healing electric power grid. Proceedings of the Power and Energy Society General Meeting - Conversion and Delivery of Electrical Energy in the 21st Century. doi: 10.1109/PES.2008.4596791
- [38] Friedl, W., Fickert, L., Schmutzner, E., & Obkircher, C. (2008). Safety and reliability for Smart-, Micro- and islanded grids. Proceedings of the SmartGrids for Distribution, IET-CIRED. CIRED Seminar.
- [39] Brown, R. E. (2009). *Electric power distribution reliability*. CRC Press, Boca Raton: Florida
- [40] IEEE Std. 1366-2003 IEEE Guide for Electric Power Reliability Indices, IEEE publications 2004
- [41] Richards, C. S., Benner, C. L., Butler-Purry, K. L., Russell, B. D. (2003). Electrical behavior of contaminated distribution insulators exposed to natural wetting. *IEEE Transactions on Power Delivery*, 18(2), 551-558.
- [42] Savadjiev, K., & Farzaneh, M. (n. d.). *Modeling of icing and ice shedding on overhead power lines based on statistical analysis of meteorological data*, 715- 721.
- [43] Brown, R. E. Frimpong, G. & Willis, H. L. Failure rate modeling using equipment inspection data.
- [44] Werner, V. G., Hall, D. F., Robinson, R. L., Warren, C. A. (n. d.) Collecting and categorizing information related to electric power distribution interruption events: Data consistency and categorization for benchmarking surveys.
- [45] Domijan, A. Matavalam, R. K., Montenegro, A., Wilcox, W. S. Diaz, L., & D'Agostini, D. J. (2004). Analysis of rain, wind, and temperature effects on power distribution interruptions. *International Journal of Power and Energy Systems*, 24(2), 51-57.
- [46] Islam, A., & Domijan, A. (2007). *Weather and reliability*. IEEE Conference.
- [47] Domijan, A., Islam, A. Wilcox, W. S., Matavalam, R. K. Diaz, J. R. Davis, L. et al. (2004). *Modeling the effect of weather parameters on power distribution interruptions*. Proceedings of the 7<sup>th</sup> IASTED Int. Conf. Power and Energy Systems, Clearwater Beach: Florida.

- [48] Domijan, A. Matavalam, R. K., Montenegro, A., Wilcox, W. S., Joo, Y. S., Delforn, L. et al. . Effects of Normal Weather Conditions on Interruptions in Distribution Systems. *Journal of Power and Energy Systems*, 203-3453
- [49] <http://www.faa.gov/asos/>
- [50] Mansoor, A. McGranaghan, M., & Forstner, K. (2004). *Quantifying reliability and service quality*. Utility Automation & Engineering T&D.
- [51] Williams, C., Kreiss, D. (2004). *Bad weather vs. power reliability: Progress Florida seeks to normalize Reliability Indices*. Utility Automation & Engineering T&D.
- [52] McDaniel, J., Williams, C., & Vestal, A. (2003). Lightning and distribution reliability-a comparison of three utilities. Transmission and Distribution Conference and Exposition,, 3, 7-12.
- [53] Mendenhall, W., & Beaver, R. J. (1991). *Introduction to probability and statistics*. Boston, Mass: PWS-Kent.
- [54] Carpaneto, E., & Chicco, G. (2004). Evaluation of the probability density functions of distribution system reliability indices with a characteristic functions-based approach. *Power Systems, IEEE Transactions*, 19(2), 724 – 734.
- [55] Anderson, P. M. (1999). *Power system protection*. IEEE Press, NJ, USA.
- [56] Aquilino, J. W. (1981). Report of transformer reliability survey- Industrial plants and commercial buildings. Proceedings of the Industrial and Commercial Power System Conference, Houston, TX
- [57] Manez, D., Schelenz, O., Chandra, R., Bose, S., de Rooij, M., & Bebic, J. (2008). *Enhanced reliability of photovoltaic system with energy storage and controls*. National Renewable Energy Laboratory, Subcontract Report NREL/SR-581-42299.
- [58] PSC Rule 25-6.0455(2) Retrieved from [www.psc.state.fl.us/rules/Rules.pdf](http://www.psc.state.fl.us/rules/Rules.pdf)
- [59] PSC Rule 25-6.0455(3) Retrieved from [www.psc.state.fl.us/rules/Rules.pdf](http://www.psc.state.fl.us/rules/Rules.pdf)
- [60] Ortmeyer, T., Dugan, R., Crudele, D., Key, T., Barker, P. (n. d.). *Utility models, analysis, and simulation tools*. SANDIA Report, Sandia National Laboratories
- [61] Lund, J., & Nguyen, S. (2009). *Transform US Smart Grid*. Utility Products.
- [62] Yang, F., Meliopoulos, A. P. S., Cokkinides, G. J., & Stefopoulos, G. K. (2007). *A comprehensive approach for bulk power system reliability assessment*. Power Tech, IEEE Lausanne–.

- [63] Dhillon, B. S. (1983). *Power system, reliability, safety, and management*. Ann Arbor Science Publishers, Michigan:USA
- [64] Roberts, N. H, Vesely, W. E., Haasl, D. F., Goldberg, F. F. (1981). *Fault tree handbook*. NUREG-942, U.S. Nuclear Regulatory Commission, Washington, DC.
- [65] Kumamoto, H, & Henely, E. J. (1996). *Probabilistic risk assessment and management for engineers and scientists*. (2<sup>nd</sup> ed.), IEEE Press, Piscataway: NJ
- [66] Billinton, R., & Allan, R. N. (1983). *Reliability evaluation of engineering systems: Concept and technics*. Plenum Press.
- [67] Billinton, R., Wenyan, L. (1991). Composite system reliability assessment using Monte Carlo approach. Proceedings of the 3<sup>rd</sup> PMAPs International Conference.
- [68] Daron, A., Borodetsky, S., Vekshtein, S., Dubi, A. (2000). *Monte Carlo approach and computer code for electric network reliability evaluation*. Proceedings of the 6<sup>th</sup> PMAPs, International Conference, Madrea: Portugal.
- [69] Carrer, P., Belvis, J., Bouissou, M., Domeruge, J., & Pestourie, J. (n. d.). *A new method for reliability assessment of electrical power supplies with standby redundancies*. SAM Conference
- [70] Bouissou, M. (2002). *Boolean Logic Driven Markov Process: A powerful new formalism for specifying and solving very large Markov models*. Proceedings of the PSAM6 Conference, Port Rico.
- [71] Bouissou, M., & Bon, J. L. (2003). A new formalism that combines advantages of fault-trees and Markov models: Boolean logic Driven Markov Process. *Reliability Engineering and System Safety*, 82(2), 149-163.
- [72] Billinton, R., Bollinger, K. (1968). Transmission system reliability evaluation using Markov Process. *IEEE Transactions on Power System and Apparatus*, 87(2), 538-547.
- [73] Billinton, R. (1970). *Power system reliability evaluation*. Gordon and Braech, Science Publishers: New York.
- [74] Billinton, R. & Allan, R. E. (1996). *Reliability evaluation of power systems* (2<sup>nd</sup> ed.). Plenum Press: New York.

## APPENDICES

## APPENDIX A: DEFINITIONS AND FORMULAE

The following are the definitions and formulae defined by IEEE (40) for reliability studies.

Note: reprinted with permission from IEEE Std. 1366-2003 IEEE Guide for Electric Power Reliability Indices © 2003 IEEE]\*, by IEEE.

The IEEE disclaims any responsibility or liability resulting from the placement and use in the described manner

### 4. Reliability Indices

#### 4.1 Basic factors

These basic factors specify the data needed to calculate the indices.

$i$  denotes an interruption event

$i_r$	-	Restoration Time for each Interruption Event
CI	-	Customers Interrupted
CMI	-	Customer Minutes Interrupted
E	-	Event
T	-	Total
$IM_t$	-	Number of Momentary $y$ Interruptions
$IM_g$	-	Number of Momentary $g$ Interruption Events
$N_r$	-	Number of Interrupted Customers
N	-	Number of Interrupted Customers for each Momentary Interruptions event during the Reporting Periods
$N_T$	-	Total Number of Customers Served for the Areas
$L_V$	-	Connected LVA load Interrupted for each Interruption Event
$L_T$	-	Total Connected LVA Load Served
CN	-	Total Number of Customers who have Experienced a Sustained Interruption during the reporting period
CNT	-	Total Number of Customers who have Experienced more than $\pi$ Sustained Interruptions and Momentary Interruption Events during the Reporting Period

From IEEE Std. 1366-2003 IEEE Guide for Electric Power Reliability Indices © 2003 IEEE\*, by IEEE. All rights reserved.

## Appendix A (continued)

- $\pi$  - Number of Interruptions Experienced by an Individual Customer in the Reporting Period  
 $T_{MED}$  - Major Event day Identification threshold value

### 4.2 Sustained Interruption Indices

#### 4.2.1 System average interruption frequency index (SAIFI)

The system average interruption frequency index indicates how often the average customer experiences a sustained interruption over a predefined period of time. Mathematically, this is given in Equation (1)

$$SAIFI = \frac{\sum \text{Total of Customers Interrupted}}{\text{Total Number of Customers Served}} \quad (1)$$

To calculate the index, use equation (2) below:

$$SAIFI = \frac{\sum N_i}{N_T} = \frac{CI}{N_T} \quad (2)$$

#### 4.2.2 System average interruption duration index (SAIDI)

This index indicates the total duration of interruption for the average customer during a predefined period of time. It is commonly measured in customer minutes or customer hours of interruption. Mathematically, this is given in Equation (3).

$$SAIDI = \frac{\sum \text{Customer Interruption Duration}}{\text{Total Number of Customers Served}} \quad (3)$$

To calculate the index, use Equation (4)

$$SAIDI = \frac{\sum Y_i N_i}{N_T} = \frac{CMI}{N_T} \quad (4)$$

From IEEE Std. 1366-2003 IEEE Guide for Electric Power Reliability Indices © 2003 IEEE\*, by IEEE. All rights reserved.



## Appendix A (continued)

### 4.2.3 Customer average interruption during index (CAIDI)

CAIDI represents the average time required to restore service. Mathematically, this is given in Equation (5)

$$\text{CAIDI} = \frac{\sum \text{Customer Interruptions Duration}}{\text{Total Number of Customers Interrupted}} \quad (5)$$

To calculate this index, use Equation (6)

$$\text{CAIDI} = \frac{\sum Y_i N_i}{\sum N_i} = \frac{\text{SAIDI}}{\text{SAIFI}} \quad (6)$$

### 4.2.4 Customer total average interruption duration index (CTAIDI)

This index represents the total average time in the reporting period that customers who actually experienced an interruption were without power. This index is hybrid of CAIDI and is similarly calculated except that those customers with multiple interruptions are counted only once. Mathematically, this is given in Equation (7)

$$\text{CTAIDI} = \frac{\sum \text{Customer Interruption Duration}}{\text{Total Number of Customers Interrupted}} \quad (7)$$

To calculate the index, use Equation (8)

$$\text{CTAIDI} = \frac{\sum T_i N_i}{\text{CN}} \quad (8)$$

Note – Is tallying Total Number of Customers Interrupted, each individual customer should only be counted once regardless of times interrupted during the reporting period. This applies to 4.2.4 and 4.2.5.

From IEEE Std. 1366-2003 IEEE Guide for Electric Power Reliability Indices © 2003 IEEE\*, by IEEE. All rights reserved.

## Appendix A (continued)

### 4.2.5 Customer average interruption frequency index (CAIFI)

This index gives the average frequency of sustained interruptions for those customers experiencing sustained interruptions. The customer is counted once regardless of the number of times interrupted for this calculation. Mathematically, this is given in Equation (9)

$$CAIFI = \frac{\sum \text{Total Number of Customers Interrupted}}{\text{Total Number of Customers Interrupted}} \quad (9)$$

To calculate the index, use Equation (10)

$$CAIFI = \frac{\sum N_i}{CN} \quad (10)$$

### 4.2.6 Average service availability index (ASAI)

The average service availability index represents the fraction of time (often in percentage) that a customer has received power during the defined reporting period. Mathematically, this is given in Equation (11)

$$ASAI = \frac{\text{Customer Hours Service Availability}}{\text{Customer Hours Service Demand}} \quad (11)$$

To calculate the index, use Equation (12)

$$ASAI = \frac{NrX (\text{Number of hours/yr}) - \sum r_i N_i}{NrX (\text{Number of hours/yr})} \quad (12)$$

Note- There are 8760 hours in a non-leap year, 8784 hours in a leap year.

### 4.2.7 Customers experiencing multiple interruptions (CEMI<sub>n</sub>)

This index indicates the ration of individual customers experiencing more than n sustained interruptions to the total number of customers served.

From IEEE Std. 1366-2003 IEEE Guide for Electric Power Reliability Indices © 2003 IEEE\*, by IEEE. All rights reserved.

## Appendix A (continued)

Mathematically, this is given in equation (13)

$$CEMI_n = \frac{\text{Total Number of Customers that experience more than } n \text{ sustained interruptions}}{\text{Total Number of Customers Served}} \quad (13)$$

To calculate the index, use Equation (14)

$$CEMI_n = \frac{CN_{(k)n}}{N_T} \quad (14)$$

Note – This index is often used in a series of calculations with  $n$  incremented from a value of one to the highest value of interest.

### 4.3 Load based indices

#### 4.3.1. Average system interruption frequency index (ASIFI)

The calculation of this index is based on load rather than customers affected. ASIFI is sometimes used to measure distribution performance in areas that serve relatively few customers having relatively large concentrations of load, predominantly industrial/commercial customers. Theoretically, in a system with homogeneous load distribution, ASIFI would be the same as SAIFI. Mathematically, this is given in Equation (15)

$$ASIFI = \frac{\sum \text{Total Connected kVA of Load Interrupted}}{\text{Total Connected kVA Served}} \quad (15)$$

To calculate the index use Equation (16)

$$ASIFI = \frac{\sum L_i}{L_T} \quad (16)$$

#### 4.3.2 Average system interruption duration index (ASIDI)

The calculation of this index is based on load rather than customers affected. Its use, limitations, and philosophy are stated in the ASIFI definition in 4.3.1. Mathematically,

From IEEE Std. 1366-2003 IEEE Guide for Electric Power Reliability Indices © 2003 IEEE\*, by IEEE. All rights reserved.

## Appendix A (continued)

this is given in Equation (17).

$$ASIDI = \frac{\sum \text{Connected kVA Duration of Load Interrupted}}{\text{Total Connected kVA Served}} \quad (17)$$

To calculate the index, use Equation (18).

$$ASIDI = \frac{\sum y_{Li}}{L_T} \quad (18)$$

### 4.4 Other indices (momentary)

#### 4.4.1 Monetary average interruption frequency index (MAIFI)

This index indicates the average frequency of momentary interruptions. Mathematically, this is given an Equation (19).

$$MAIFI = \frac{\sum \text{Total Number of Customer Momentary Interruption}}{\text{Total Number of Customers Served}} \quad (19)$$

To calculate this index, use Equation (20)

$$MAIFI = \frac{\sum IM_i N_{mi}}{N_T} \quad (20)$$

From IEEE Std. 1366-2003 IEEE Guide for Electric Power Reliability Indices © 2003 IEEE\*, by IEEE. All rights reserved.

## ABOUT THE AUTHOR

Arif Islam received his B.Tech. degree in Electronics Engineering from A.M.U., India in 1994 and his M.S. degree in electrical and computer engineering from the University of Florida, Gainesville. He joined Siemens in 1994 and has worked in the industry for more than a decade executing many multi-million dollar projects. He enjoys research and produces time bound results utilizing his knowledge, experience and management tools. He is now at the University of South Florida as the Deputy Director of the Power Center for Utility Explorations (PCUE) and the Power & Energy Applied Research Laboratory. His fields of interest include smart grid, power reliability, power electronics, motor and drive systems, understanding natural and man-made hazards, and the evaluation of alternative resources of energy. He has been successful in receiving on average, 7 million dollars of project grants from the industry as well as from federal and state agencies. Currently he is the Co- Principle Investigator for more than eight major projects in the smart grid area.